

Measuring Microscopes MF/MF-U Series

Catalog No. E14003



Meeting performance expectations for measuring
microscopes

Mitutoyo



Microscopes that also serve as measuring instruments

Expectations for Measuring Microscopes

A measuring microscope can be used to perform both measurement and observation, inspecting a variety of objects including semiconductors, electronic and electrical components, automobile precision components, resin moldings, tools, and medical products. For example, this type of microscope can be used to measure an object that is too soft for contact measurement or the diameter of a hole that is too small for a measurement probe to contact.

A balance between optical performance, overall accuracy, and ease of use is an important requirement for a measuring microscope. A measuring microscope enables you to observe elements that have either been invisible or difficult to see and measure them. Mitutoyo believes that expectations for measuring microscopes will continue to grow and that user friendliness, high measurement data throughput, and environmental friendliness will be demanded at the same time. To play our part in supporting essential technologies in the industry, we will continue to provide high-quality, high-definition measuring microscopes, while staying true to our commitments and beliefs.



From Design and Development to Support after Delivery

Mitutoyo designs, develops and manufactures all microscope parts – including those for the body, such as the lenses and optical tube – and the highly accurate built-in digital scale. Our in-house design and development processes allow us to, proactively, offer consultation on special requirements and respond to customer requests, such as those for customized fabrication.

Mitutoyo carefully delivers the microscope from the production plant to its desired destination*, and then installs and adjusts it there. The packaging box is recyclable, which enables the customer to eliminate as much waste as possible at the delivery destination. After adjustment, customers can sign a maintenance contract or use our reliable after-sales services according to their needs, which ensures that they can confidently use their Mitutoyo microscope for a long time to come.

*If a dedicated delivery service is used.

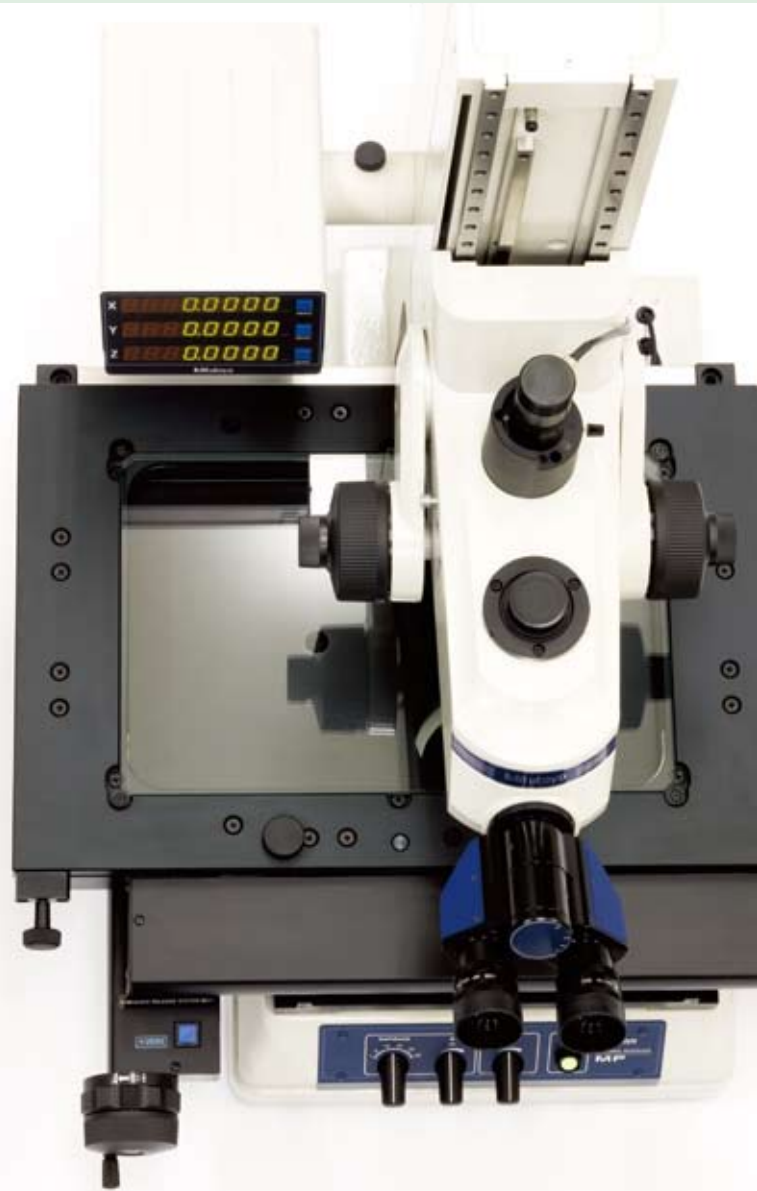



In Pursuit of Optical Performance — The Essence of Microscopy —

These microscopes use an optical design inherited from the previous B Series for the optical tube and objective lens to reduce flare within the optical system as much as possible and so enable the clear display of subtle details of inspected objects. With this series, even the surface of black resin can also be clearly observed in high contrast. The MF-U Series is equipped with the proven FS optical system metal microscope head and displays clear images with high color reproducibility in which the three prime colors are corrected. (The plan apochromat specifications are used for the objective lens*.) For the C Series, an LED- or halogen-based lighting system can be used. Higher lighting efficiency and sufficient illuminance within the optical system provide an environment for high-magnification measurement and bright-field and dark-field observation in which you can work efficiently without getting tired.



*Specifications according to which aberrations across the image surface and chromatic aberrations in the wave length range of the three primary colors (blue, yellow and red) are corrected.

In Pursuit of Measuring Accuracy — Close to JIS Grade 0 —

X and Y axes: $(2.2+0.02L)\mu\text{m}$ or less

Reference) Measuring accuracy of each axis of a JIS B 7153 measuring microscope (at 20°C)

Grade 0: $(2+0.01L)\mu\text{m}$ or less

Grade 1: $(4+0.02L)\mu\text{m}$ or less L: measuring length (mm)

(Common to MF C, MF-U C, MF D and MF-U D)

Example

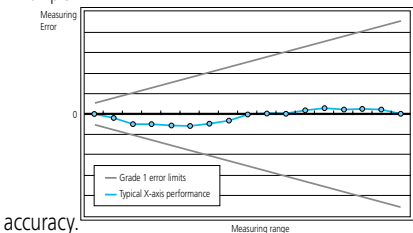

A measuring microscope must have high level optical performance and overall measuring accuracy. The C Series realizes the measuring accuracy stipulated by the above standards for every stage size*.

This series is useful for any measurement because it offers both long stroke measurement and high accuracy at the same time.

*Conforms to the JIS B 7153 measurement method for the X and Y axes. The above measuring accuracy graph is an example and does not represent all main unit accuracies.

The digital scale built into the microscope is a photoelectric type transmission linear encoder with a maximum response speed of 50m/min. This highly accurate encoder was developed in an underground laboratory where the world's best scale accuracy evaluation technique is available. Mitutoyo was the first manufacturer to acquire accreditation for calibrating line standards (standard scales up to 500mm long) in Japan.



Line standard calibration unit

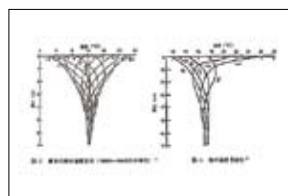

Underground temperature fluctuation chart

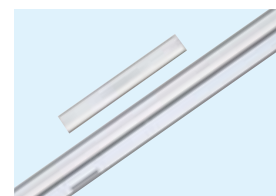

Glass scales

For Safe Use — Traceability to International Standards —

To establish and maintain the traceability of customer measuring tools and instruments, Mitutoyo uses length standards that directly lead to the national standards in Japan to calibrate the standard used to calibrate measuring tools and instruments. Mitutoyo also offers temperature calibration services necessary for highly accurate length measurement.

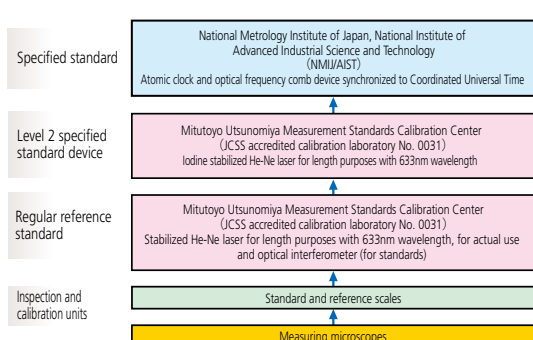

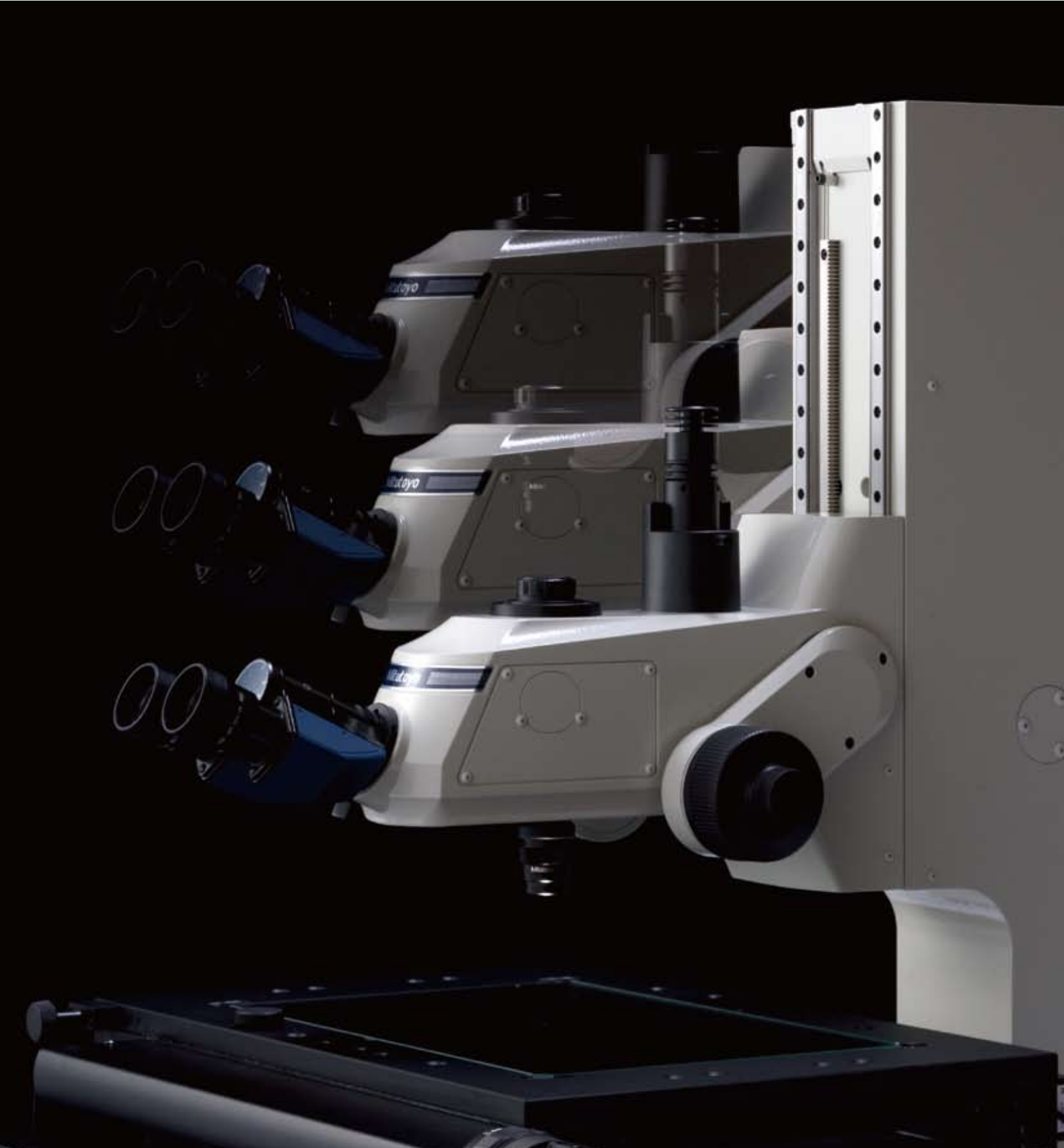



Solutions Provided by Measuring Microscopes

Observation and Inspection of Small Areas

By using various types of illumination, the MF Series can more precisely reproduce the colors and shapes of objects that are observed and inspected.

The MF-U Series microscopes are high value-added instruments that offer microscope observation functions such as dark-field mode (to observe surface scratches and small steps, which are difficult to see in bright-field mode), simple polarization (to observe coloration or contrast through the polarizer or analyzer using polarization properties), and differential interference (to observe small surface steps and other elements in color contrast using the polarization filter with a differential interference prism), as well as measurement functions.

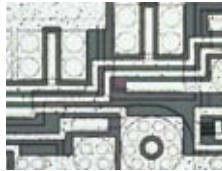

Bright-field observation



Dark-field observation



Polarized observation

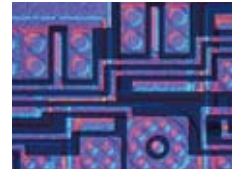

Differential interference observation



Easy Image Photography

Anyone can easily photograph microscope images by attaching a digital camera to the microscope. Because a general-purpose C-mount adapter is used, any digital camera model that supports C-mounting can be attached. For example, several people can simultaneously analyze and evaluate the microscope image displayed on the monitor, or generation of an inspection chart attached to the image can be automated.



MF-B2010C + Vision Unit



Microscope-Based High-Resolution Measurement

It is possible to build a manual image measurement system by equipping a measuring microscope with the image measurement option (the Vision Unit). Because the software constantly transmits stage displacements, measurements within the camera imaging range (on the screen) as well as those wider than the screen are supported. In addition, automatic edge detection provides an efficient measurement environment with a high throughput.

However, eyepiece resolution might be superior to camera resolution in some cases. For example, the surface of a molded item made of black resin might be clearer to the naked eye than to the camera (monitor observation). Therefore, a measuring microscope that also enables you to see the surface and other elements is said to be a system that has a very high added value. It is recommended to connect the two-dimensional data processing unit QM-Data 200 (a dedicated control unit) to the measuring microscope for such dimensional measurement.



MF-UB2010C + QM-Data200



Height Measurement with a High Focus Repeatability New design For details, see page 31.

Focus repeatability is important when measuring a vertical step or other element using the microscope. In particular, measurement errors due to the depth of focus of the objective lens are inevitable.

The MF and MF-U Series measuring microscopes have a focus pilot, which enhances focus repeatability. The focus pilot is mounted on the TV camera port section in the main unit as an add-on unit* and enables focusing position detection with high accuracy and repeatability. This realizes higher repeatability than a visual check and decreases variation in measured values caused by human error.

Two types of focus patterns are available, either of which can be selected according to the size of the part to be focused on or the surface state, material, or other properties of the inspected object. A clear, bright, high-intensity LED (green or red) is employed as the light source. The focus pattern, for which brightness can be steplessly adjusted, can be checked on the eyepiece or TV monitor. This substantially improves measurement throughput.

* This is a factory installed option for the MF-U Series.

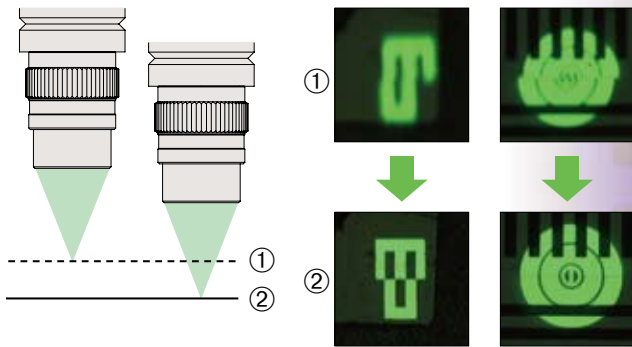



more details

Wide-Field Observation New design
(Common to MF C, MF-U C, MF D and MF-U D)



The best-in-class eyepiece field number* of 24mm (for WF10X) offers a wide viewing field that helps prevent extended observation or measurement from affecting your eyes or causing fatigue. The WF10X eyepiece, which was designed at the same time as the C Series, has wider diopter adjustment ranges on the left and right sides than older products.

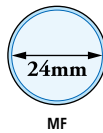

*Width of an inspected object that can be seen across the whole viewing field when a 1X objective lens is used

LED and Halogen Light Options for Transmitted and Reflected Illumination New design
(Common to MF C, MF-U C, MF D and MF-U D)



Transmitted LED illumination unit (Common to MF/MF-U Series) Reflected LED illumination unit (for MF Series) Reflected LED illumination unit (for MF-U Series)

An LED or halogen light can be selected for the coaxial illumination in the main unit. While the conventional halogen light can be used for observation and measurement, the LED light can also be selected if you want to reduce the time lost to replace a failed halogen bulb with a new one and need high intensity illumination that quickly responds to brightness adjustment.

The LED light has a long working life*¹ and will not suddenly fail. In addition, the visibility, brightness and coloration are constant because, unlike fluorescent tubes, the LED light is free from glare and changes in color temperature. This means less eye fatigue after extended observation. Because the LED consumes little power and emits little heat radiation, measurement is economical and produces less heat-induced effects on inspected objects*². In addition, this light source is impact resistant and does not contain environmental toxins.

All the models in the MF and MF-U Series have transmitted and reflected illumination aperture-diaphragms as standard to enable observation and measurement with less light diffraction.

*1: The working life will be shorter if the maximum illuminance is always used.
*2: The LED light for MF/MF-U Series incorporates a quiet cooling fan to further reduce heat effects.

High Visibility Digital Display
(Common to MF C and MF-U C)



Front of display



Rear of display

Because the resolution can be switched to 1μm, 0.5μm, or 0.1μm for the digital display (two or three axes), which is a standard accessory for all models, high-discrimination measurement can be performed. The zero-set, direction changeover, and smoothing functions are also standard. (Zero can be set using the switch near the X or Y handwheel.)

Because the general-purpose RS-232C format is adopted for data transfer, data can be output to a standard printer or personal computer. It is also possible to output the display readings to spreadsheet software. The digital display can be installed on the left or right* side of the column.

*Factory installed option.

Highly Rigid Column Base
(Common to MF C, MF-U C, MF D and MF-U D)

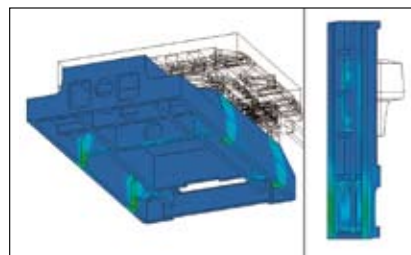

Column

The base that supports the column holding the optical tube and the rest of the microscope must be absolutely rigid to enable observation and measurement using any amount of magnification.

This series has been repeatedly evaluated from various aspects including a drop test*, transportation test*, and smoothing test and provides steady vision and consistent accuracy over the entire stroke.

To enhance rigidity, horizontal ribs have been added within the column. The power supply section is located outside the base to reduce heat effects for higher base rigidity and highly accurate measurement.

*Proprietary Mitutoyo tests executed using appropriate procedures.



LED illumination



Halogen illumination

Quick Release Mechanism*1 and Zero-set Switch Incorporated*2 (Common to MF C and MF-U C)

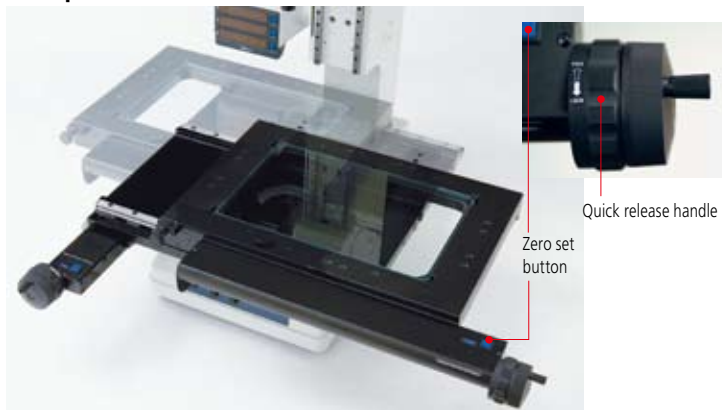

The stage movement can be switched between extremely coarse and fine (FREE and LOCK) by using the quick release handles on the X and Y handles. These handles are useful for freeing the stage when the distance to the measurement position is long or you want to quickly return to a reference position.

Because this mechanism uses the twist roller method, switching causes little impact and enables smooth movement. Because the display zero-set switches are located near the handles*2, you can focus on the eyepiece during measurement and keep your hand near the handle almost all the time except when adjusting the focus.

*1: Patent pending (Japan)

*2: The zero-set buttons are located on the X and Y axes, not the Z axis.

Stage Variations Including Long Stroke (Common to MF C and MF-U C)

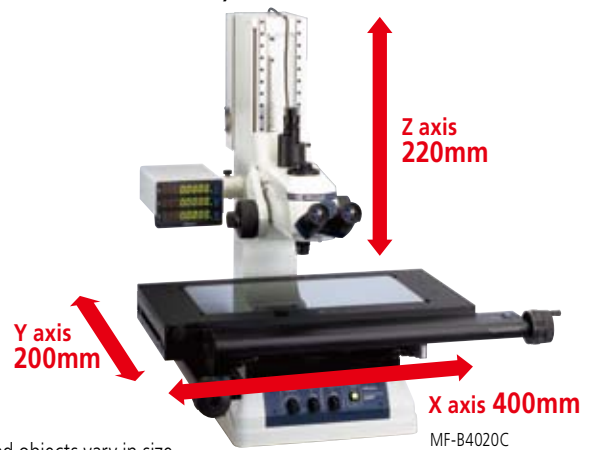

Inspected objects vary in size.

Widely used in every industry, this series provides many measurement stroke variations.

This series offers a stage for long stroke measurement of 400×200×220mm in X, Y and Z. This is useful when measuring printed circuit boards, shafts, knife tools and other objects. Although the standard model has a Z-axis range of 220mm, the Z axis can be extended with a column upgrade.

A swivel rotation mechanism* is also provided as standard. This mechanism is useful when fixing an inspected object in parallel with the table movement direction.

*Only for models with a Y-axis range of 170mm or longer

Z-Axis Handles Provided on Both Sides of Standard Model (MF C and MF-U C)



Because the Z axis handles are placed on both sides of the column in standard models, the user can easily use one of them regardless of handedness.

The digital display can also be installed on either side of the column to set up an environment suited to the user's dominant hand.

Ergonomics have also been taken into consideration, and the handle is located in a position where a user of shorter stature can comfortably turn it.

Tilting Optical Tube of Standard Model (MF-U C and MF-U D)



Comfortable observation is possible because the eye point can be adjusted to a position suitable for the user's stature.

The angle of the column can be fixed anywhere between 0° and 30°.

The reticle in the optical tube can be replaced.

Sliding Nosepiece (Factory installed option for MF C and MF D)



Usually, only one objective lens can be attached to an MF instrument (limited compensation optical system), and this must be replaced to change the magnification.

Because up to two objective lenses can be attached to the sliding nosepiece, the magnification can be quickly changed when this option is specified.

Note) An external illumination source cannot be attached.

Measuring Microscopes

MF Series (MF C)



MF-B1010C

* The binocular tube (eyepiece) and illumination unit are optional accessories.



MF-B2010C

* The binocular tube (eyepiece) and illumination unit are optional accessories.

Features

- Observation with a clear and flare-less erect image and a wide field of view
- Measuring accuracy that is the highest in its class (and conforms to JIS B 7153)
- ML series, high-NA objectives that are specially designed for the MF series (long working distance type)
- Illumination unit (reflected/transmitted) selectable from a high-intensity LED or halogen bulb (required)
- Variable aperture diaphragm (reflected/transmitted) allows observation measurement while suppressing light diffraction
- Variety of standardized stages in sizes up to 400×200mm
- Quick-release mechanism useful for moving the stage quickly when measuring workpieces that are large in size or quantity
- Coarse/fine feed handles equipped as standard on both sides allow precise focus and observation measurement regardless of handedness
- High-magnification eyepiece observation up to 2000X
- Standard measuring microscope that has a wide variety of optional accessories including a Vision Unit and various digital CCD cameras
- Low-noise design

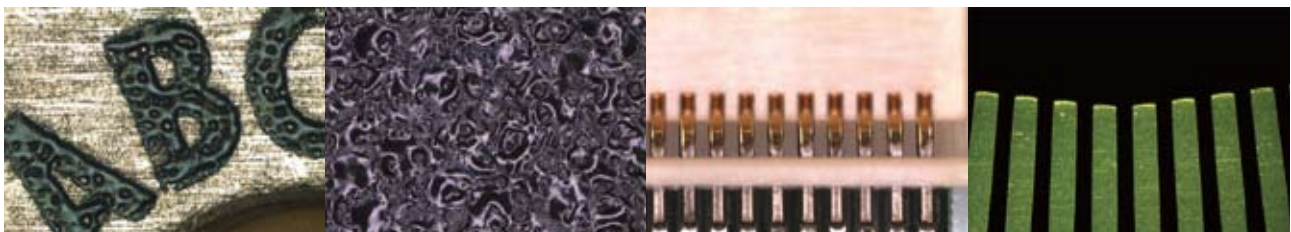



MF-B2017C

* The binocular tube (eyepiece) and illumination unit are optional accessories.

MF-B3017C

* The binocular tube (eyepiece) and illumination unit are optional accessories.

MF-B4020C

* The binocular tube (eyepiece) and illumination unit are optional accessories.

Specifications

Without Z-axis scale	Model No.	MF-A1010C	MF-A2010C	MF-A2017C	MF-A3017C	MF-A4020C	
Order No.		176-662*	176-663*	176-664*	176-665*	176-666*	
With Z-axis scale	Model No.	MF-B1010C	MF-B2010C	MF-B2017C	MF-B3017C	MF-B4020C	
Order No.		176-682*	176-683*	176-684*	176-685*	176-686*	
Optical tube (eyepiece(s) required)	Monocular or binocular (angle of column: 25°) Standard TV camera port for all models, reticle (broken cross-hair, line width: 5µm), optical path switching (observation/TV camera = 50/50)						
Observation image	Erect image						
Observation method	Bright-field observation						
Eyepiece (optional) Adjustable diopter	10X (eyepiece field number: 24), 15X, 20X Note: Monocular - one 10X eyepiece provided as standard; Binocular - two 10X eyepieces provided as standard						
Objective (optional)	ML objective 3X (provided as standard), 1X, 5X, 10X, 20X, 50X, 100X						
Z axis	Max. workpiece height	150mm		220mm			
	Feed mechanism	Coaxial coarse and fine feed, handles on both sides (coarse: 30mm/rotation, fine: 0.2mm/rotation)					
Illumination unit	LED or halogen is required.						
Illumination filter	One GIF filter is provided as standard (and mountable for both transmitted and reflected illumination)						
Stage	Measurement range	100x100mm	200x100mm	200x170mm	300x170mm	400x200mm	
	Tabletop size	280x280mm	350x280mm	410x342mm	510x342mm	610x342mm	
	Effective stage glass size	180x180mm	250x150mm	270x240mm	370x240mm	440x240mm	
	Swiveling angle	—		±5° (left)		±3° (left)	
	Maximum table loading (glass top)	10kg		20kg		15kg	
	Quick-release mechanism	Provided as standard for the X and Y axes					
	Zero-set button	Provided as standard for the X and Y axes (and for the Z axis only for the MF-B type)					
Measurement system	High-accuracy digital scale*1						
Measuring accuracy*2 (X and Y axes, when not loaded)	(2.2+0.02L)µm, L: measuring length(mm)						
Digital display	Minimum reading	1/0.5/0.1µm switchable					
	Display axes	X and Y (or X, Y, and Z only for the MF-B type)					
	Functions	Zero-setting, direction switching, RS-232C output					
Main unit dimensions (WxDxH)	562x730x667mm	624x745x667mm	632x892x782mm	682x892x782mm	757x907x782mm		
Main unit mass	65.5kg	69.5kg	130kg	138kg	144kg		
Control unit dimensions and mass	114(W)x330(D)x90.5(H)mm 2.0kg						
Maximum power consumption (with the illumination unit)	LED: 65W Halogen bulb: 120W						

Replacement halogen bulb (reflected/transmitted)	Standard: 513667 (12V/50W)
	Long life: 12BAB345 (12V/50W)

Note: The following suffixes are added to the order No. (e.g.: 176-662-10) to specify the User Manual's language: -10 for English; -11 for Chinese; No suffix for Japanese.

*1: Patent registered in Japan *2: Measured in conformance with JIS B 7153

Universal Measuring Microscopes

MF-U Series (MF-U C)



MF-UB1010C

* The turret, objectives and illumination unit are optional accessories.



MF-UB2010C

* The turret, objectives and illumination unit are optional accessories.

Features

- Observation with a clear and flare-less erect image and a wide field of view
- Measuring accuracy that is the highest in its class (and conforms to JIS B 7153)
- Proven M Plan Apo/BD Plan Apo/G Plan Apo series, high-NA objectives from the FS optical system (long working distance type)
- Integration of metallurgical and measurement microscope functions provides a high-resolution observation and high-accuracy measurement solution
- Illumination unit (reflected/transmitted) selectable from a high-intensity LED or halogen bulb (required)
 - * Only the halogen light source for transmitted illumination is provided as standard accessory. A separate light source for transmitted illumination must be ordered additionally as optional accessory.
- Variable aperture diaphragm (reflected/transmitted) allows observation measurement while suppressing light diffraction
- Variety of standardized stages in sizes up to 400×200mm
- Quick-release mechanism useful for moving the stage quickly when measuring workpieces that are large in size or quantity
- Coarse/fine feed handles equipped as standard on both sides allow precise focus and observation measurement regardless of handedness
- High-magnification eyepiece observation up to 4000X (when using M Plan Apo SL200X)
- Standard measuring microscope that has a wide variety of optional accessories including a Vision Unit and various digital CCD cameras
- Low-noise design

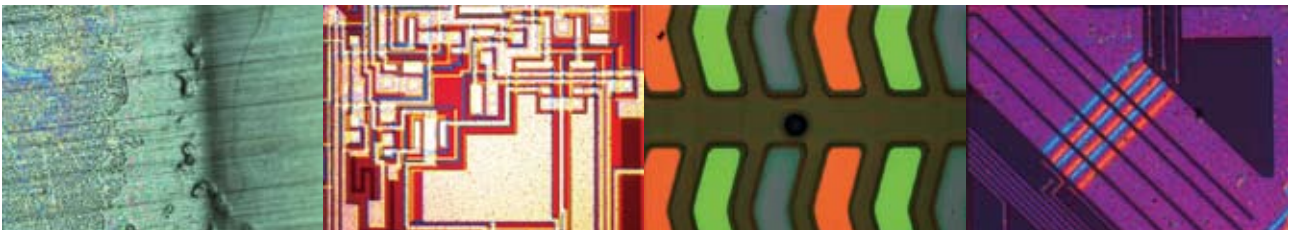



MF-UB2017C

* The turret, objectives and illumination unit are optional accessories.



MF-UB3017C

* The turret, objectives and illumination unit are optional accessories.



MF-UB4020C

* The turret, objectives and illumination unit are optional accessories.

Specifications

BF (bright-field)	Without Z-axis scale	Model No.	MF-UA1010C	MF-UA2010C	MF-UA2017C	MF-UA3017C	MF-UA4020C
	With Z-axis scale	Order No.	176-668*	176-669*	176-670*	176-671*	176-672*
BD (bright-field/dark-field)	Without Z-axis scale	Model No.	MF-UC1010C	MF-UC2010C	MF-UC2017C	MF-UC3017C	MF-UC4020C
	With Z-axis scale	Order No.	176-674*	176-675*	176-676*	176-677*	176-678*
	Without Z-axis scale	Model No.	MF-UD1010C	MF-UD2010C	MF-UD2017C	MF-UD3017C	MF-UD4020C
	With Z-axis scale	Order No.	176-694*	176-695*	176-696*	176-697*	176-698*
Optical tube		Tilting trinocular tube (angle of column: 0 to 30°), Siedentoph type (pupil distance adjustment: 51 to 76mm), built-in 1X tube lens, reticle (broken cross-hair, line width: 5µm), optical path switching (observation/TV camera = 50/50)					
Observation image		Erect image					
Observation method		BF, DF (only for MF-UC and UD types), simple polarization, differential interference					
Eyepiece (optional) Adjustable diopter		10X (eyepiece field number: 24, two eyepieces provided as standard), 15X, 20X					
Turret (required)	Bright-field (BF)	Adjustable manual turret or adjustable power turret (Select one.)					
	Bright-field/dark-field (BD)	Adjustable manual turret or adjustable power turret (Select one.)					
Objective (optional)	Bright-field (BF)	All lenses including the M Plan Apo, M Plan Apo SL, and G Plan Apo series					
	Bright-field/dark-field (BD)	All lenses including the BD Plan Apo and BD plan Apo L series					
Z axis	Max. workpiece height	150mm			220mm		
	Feed mechanism	Coaxial coarse and fine feed, handles on both sides (coarse: 10mm/rotation, fine: 0.1mm/rotation)					
Illumination unit		LED or halogen is required.					
Illumination filter		One GIF filter is provided as standard (and mountable for both transmitted and reflected illumination)					
Stage	Measuring range	100x100mm	200x100mm	200x170mm	300x170mm	400x200mm	
	Tabletop size	280x280mm	350x280mm	410x342mm	510x342mm	610x342mm	
	Effective stage glass size	180x180mm	250x150mm	270x240mm	370x240mm	440x240mm	
	Swiveling angle	—			±5° (left)		±3° (left)
	Maximum table loading (glass top)	10kg			20kg		15kg
	Quick-release mechanism	Provided as standard for the X and Y axes					
Zero-set button		Provided as standard for the X and Y axes (and for the Z axis only for the MF-UB and -UD types)					
Measurement system		High-accuracy digital scale*1					
Measuring accuracy*2 (X and Y axes, when not loaded)		(2.2+0.02L)µm, L: measuring length(mm)					
Digital display	Minimum reading	1/0.5/0.1µm switchable					
	Display axes	X and Y (or X, Y, and Z only for the MF-UB and -UD types)					
	Functions	Zero-setting, direction switching, RS-232C output					
Main unit dimensions (WxDxH)		562x730x667mm	624x745x667mm	632x892x782mm	682x892x782mm	757x907x782mm	
Main unit mass		65.5kg	69.5kg	130kg	138kg	144kg	
Control unit dimensions and mass		114(W)x330(D)x90.5(H)mm				2.0kg	
Maximum power consumption (with the illumination unit)		LED: 70W Halogen bulb: 70W*3					

* Note: The following suffixes are added to the order No. (e.g.: 176-668-10) to specify the User Manual's language: -10 for English; -11 for Chinese; No suffix for Japanese.

*1: Patent registered in Japan *2: Measured in conformance with JIS B 7153 *3: The value only in a transmitted illumination

Replacement halogen bulb (transmitted)	Standard: 513667 (12V/50W)
	Long life: 12BAB345 (12V/50W)

Replacement halogen bulb (reflected) (separate light source)	For details, see p.26.
--	------------------------

Options System Diagrams

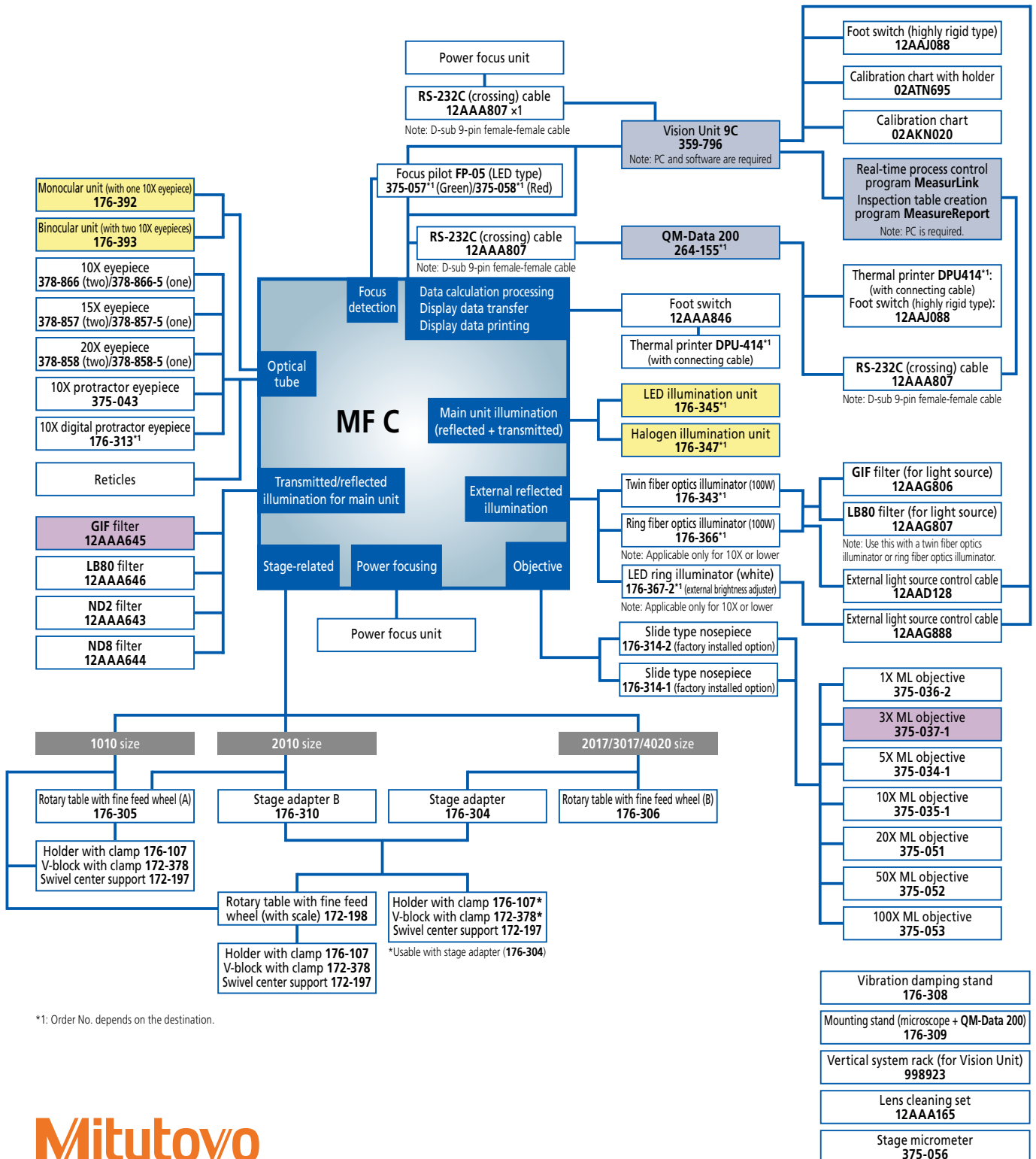

*1: Order No. depends on the destination.

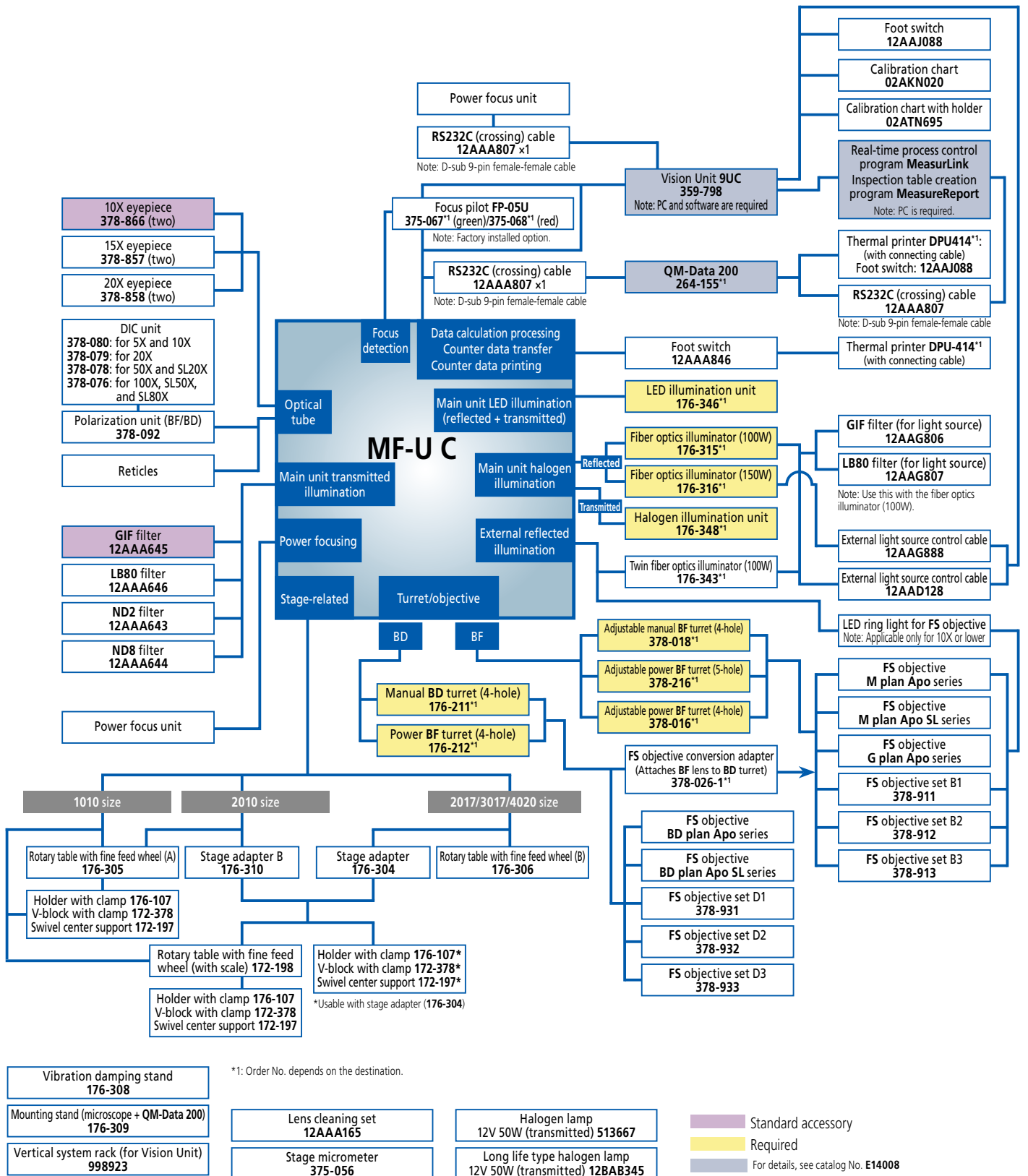

Motor-Driven Measuring Microscopes MF/MF-U Series (MF D / MF-U D)



To the next stage



MF-G2017D

- * The binocular tube, eyepieces, and LED illumination unit are optional accessories.
- * A separate LED control unit and control unit are included.



MF-UG4020D

- * The turret, objective lenses, and LED illumination unit are optional accessories.
- * A separate LED control unit and control unit are included.



MF-UE2017D

- * The turret, objective lenses, and LED illumination unit are optional accessories.
- * A separate LED control unit and control unit are included.

Features

- The measuring microscope's X, Y, and Z axes are now motor driven, and the stage can be operated from a remote control box. A joystick is used to operate the X and Y axes, and a jog shuttle is used to operate the Z axis, thus realizing a natural feeling when handling the equipment. Furthermore, these microscopes are equipped with a Z limit that you can use to set the lower limit of the Z-axis movement, which enables you to prevent the objective lens from colliding with the workpiece.
- The operator is relieved from fatigue resulting from repeated handle-turning.
- Installing a vision unit makes it possible to perform vision AF (auto focus).^{*1} For the MF-U power type and MF-U power LAF type, selecting the power turret makes it possible for the microscope to automatically recognize the position of the objective lens in the vision unit.^{*2}
- A power model lineup with large stage sizes ranging from 200×170mm to 400×200mm
- A button for coarse and fine feed switching and speed-adjustment function that are highly useful during long stroke sliding and fine positioning, are provided as standard equipment.
- The buttons on the remote control box, which is used to perform operations, have been placed to provide operations that feel natural.
- The remote control box is standard equipped with a data output button and counter reset buttons for the X, Y, and Z axes, which enables you to perform a variety of operations remotely.
- Products equipped with LAF (laser auto focus) are also included in the lineup of MF-U power products, which improves the efficiency of the focusing operation. Models that have LAF are equipped not only with the normal Just Focus (JF) function, but also with the Tracking Focus (TF) function that maintains the focus as the stage moves. These functions cater to focusing requirements in a variety of situations, reducing the amount of work that the operator has to perform.

^{*1}: A separate vision AF cable (No. 12AAN358) is required.
^{*2}: A separate RS-232C cable (No. 12AAA807) is required.



Motor Driven

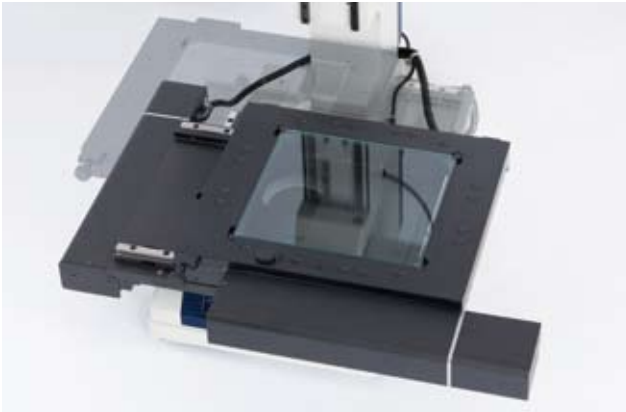

The X, Y, and Z axes are all motor driven. A joystick is used to operate the X and Y axes, and a jog shuttle is used to operate the Z axis, so operations during measurement can be performed from the remote control box.

This eliminates the conventional handle-turning and focusing operations, reducing fatigue for the operator.

The X and Y axes are driven with a maximum feed speed of 40mm/s and the Z axis with a maximum feed speed of 20mm/s. The lineup includes models that have large stages with sizes ranging from 200x170mm to 400x200mm.

Furthermore, the change to a motor-driven Z axis enables you to use the new vision AF function, provided you also use the optional vision unit.*1

*1: A separate vision AF cable (No. 12AAN358) must be connected.

Counter Display



A digital counter with a large display providing good visibility and reset buttons is included as standard equipment. This counter is also equipped with the following standard functions: display resolution switching, zero-set, direction changeover, and smoothing. While the display is large, the counter is thin. Because the counter's mounting position can be freely changed, the counter can be placed in the optimum position for the operator.



Calculation Processor

QM-Data200



* Combination of the MF-G2017D and the QM-Data200

Vision Unit



* Combination of the MF-G2017D, the 10D vision unit, and a vision AF cable

While our motor-driven measuring microscopes inherit the options and functions of our manually operated measuring microscopes, they have even greater expandability. As with our conventional measuring microscopes, our motor-driven measuring microscopes can be equipped with the "QM-Data200" two-dimensional data processing unit and the "Vision Unit" manual image measurement system that detects edges with its installed digital camera.

It is now possible to perform vision AF by using a vision AF cable together with a vision unit, thanks to the new motor drive.

Auto Focus

Vision AF (Common Option)

By using an optional vision unit and vision AF cable, you can perform vision AF. In the vision unit software QSPAK, the position in the acquired image data with the highest contrast is detected and the auto focus operation performed. This operation can be conducted faster than carrying out focusing with the naked eye, which contributes to reduction in operation time and operator fatigue.

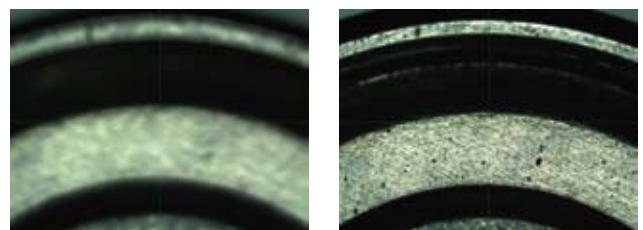

Mitutoyo

Motor Driven (Option for MF-U Power Product and MF-U Power LAF Product)



A turret must be selected for the MF-U power product and MF-U power LAF product. By selecting the power turret and equipping the measuring microscope with an optional vision unit, it is possible to change and detect the turret position.*1

This is a new function that is available in the QSPAK VUE version 4.1 and subsequent versions of the 10D vision unit software.

You can use the software to change and automatically detect the turret position, so there is no longer any need to handle the turret. Furthermore, this also fixes the problem of forgetting to change calibration values when you change the magnification, thereby providing you with a system that is more reliable and easy to use.

*1: A separate RS-232C cable (No. 12AAA807) is required.

Turret Position Display in QSPAK

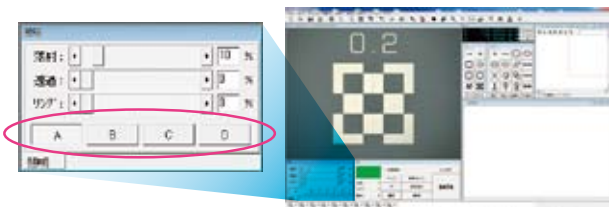

*This image corresponds to 4-hole power turrets and 4-hole turrets with sensors.

Laser Auto Focus (Power LAF Type Only)

LAF (laser auto focus) can be performed by the power LAF product. By employing AF that uses the TTL (Through The Lens) method, in which a semiconductor laser beam with a wavelength of 690nm passes through the lens, these microscopes can perform AF even on minutely-small areas.

Laser auto focus has better repeatability than focusing with the naked eye, and it can be used to measure heights. Furthermore, the following two types of focus functions are equipped as standard: JF (Just Focus), which can be used to target the laser on the point where you want to focus in order to detect the height, and TF (Tracking Focus), which always tracks the focus position.

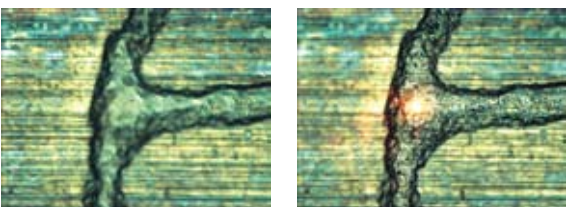

Specifications for MF D

Model No.	MF-G2017D		MF-G3017D	MF-G4020D
Order No.	176-781*		176-782*	176-783*
Optical tube (eyepiece(s) required)	Monocular or binocular (angle of column: 25°)			
Observation image	Standard TV camera port for all models, reticle (broken cross-hair, line width: 5µm), observation/TV camera = 50/50			
Observation method	Erect image			
Observation method	Bright-field observation			
Eyepiece (optional) Adjustable diopter	10X (eyepiece field number: 24), 15X, 20X Note: Monocular - one 10X eyepiece provided as standard; Binocular - two 10X eyepieces provided as standard			
Objective (optional)	ML objective 3X (provided as standard), 1X, 5X, 10X, 20X, 50X, 100X			
Z axis	Max. workpiece height	220mm		
	Feed mechanism	Motordrive (Maximum measuring speed: 20mm/s)		
Illumination unit (required)	LED	Transmitted: Telecentric, built-in aperture diaphragm, white LED light source, stepless brightness adjustment, equipped with cooling fan Reflected: Kohler illumination with adjustable aperture diaphragm, white LED light source, stepless brightness adjustment Control unit: Power switch (main switch), AC power supply input connector (100 to 240V)		
	Halogen	Transmitted: Telecentric, built-in aperture diaphragm, 12V/50W halogen lamp, stepless brightness adjustment, with cooling fan Reflected: Kohler illumination with adjustable aperture diaphragm, 12V50W halogen lamp, stepless brightness adjustment with cooling fan Control unit: Power switch (main switch), AC power supply input connector (100 to 240V)		
Illumination filter	One GIF filter is provided as standard (and mountable for both transmitted and reflected illumination)			
Stage	Measurement range	200×170mm	300×170mm	400×200mm
	Tabletop size	410×342mm	510×342mm	610×342mm
	Effective stage glass size	270×240mm	370×240mm	440×240mm
	Swiveling angle	±5°		±3°
	Maximum table loading (glass top)	20kg		15kg
Measurement system	High-accuracy digital scale*1			
Measuring accuracy*2 (X and Y axes, when not loaded)	(2.2 + 0.02L)µm, L: measuring length (mm)			
Digital display	Minimum reading	1/0.5/0.1µm switchable		
	Display axes	X, Y and Z axes		
	Functions	Zero-setting, direction switching		
Remote BOX	Joystick (X and Y axes drive), lock button (X and Y axes), speed adjustment (X,Y and Z axes), coarse/fine adjustment button (X, Y and Z axes) Jog shuttle (Z axis drive), limit setting (Z axis), emergency stop switch, power source backup switch AF button (vision auto focus): effective when connecting to vision unit (optional) Reset button (X, Y and X axes counter), data output button			
Main unit dimensions (WxDxH)	632×892×782mm	682×892×782mm	757×907×782mm	
Main unit mass	150kg	158kg	164kg	
Control unit dimensions	355×364×106.5mm			
Main unit mass	7kg			
Dimensions for control unit for illumination unit (WxDxH)	114×365×96mm			
Mass for control unit for illumination unit	LED: 3.5kg, halogen: 4kg			
Maximum power consumption	230W			

* To denote your AC line voltage add the following suffixes to the order No.: A for UL/CSA, D for CEE, E for BS, DC for China, K for EK, C for Taiwan, No suffix is required for JIS/100V

*1: Patent registered in Japan

*2: Measured in conformance with JIS B 7153.

Specifications for MF-UD

		Motorized			Motorized LAF		
Without Z-axis scale	Model No.	MF-UG2017D	MF-UG3017D	MF-UG4020D	MF-UE2017D	MF-UE3017D	MF-UE4020D
	Order No.	176-784*	176-785*	176-786*	176-790*	176-791*	176-792*
With Z-axis scale	Model No.	MF-UH2017D	MF-UH3017D	MF-UH4020D	MF-UF2017D	MF-UF3017D	MF-UF4020D
	Order No.	176-787*	176-788*	176-789*	176-793*	176-794*	176-795*
Optical tube (eyepiece: required)		Built-in 1X tube lens, reticle (broken cross-hair, line width: 5μm), observation TV camera = 50/50 Built-in 1X tube lens, reticle (broken cross-hair, line width: 5μm), observation TV camera = 50/50					
Observation image		Erect image					
Observation method		BF, DF (only for MF-UH and UF types), simple polarization, differential interference					
Eyepiece (optional) Adjustable diopter		10X (eyepiece field number: 24, two eyepieces provided as standard), 15X, 20X					
Turret (required)	Bright-field (BF)	Adjustable manual turret or adjustable power turret (Select one.)			Manual turret with BF sensor, adjustable power turret*1		
	Bright-field/dark-field (BD)	Manual turret or power turret (Select one.)			Manual turret with BD sensor, power turret*1		
Objective (optional)	Bright-field (BF)	M Plan Apo, M Plan Apo SL, G Plan Apo series					
	Bright-field/dark-field (BD)	BD Plan Apo, BD Plan Apo SL series					
Z axis	Max. workpiece height	220mm					
	Feed mechanism	Motor drive (measuring speed: max. 20mm/s)					
Illumination unit (required)	LED	Transmitted: Telecentric, built-in aperture diaphragm, white LED light source, stepless brightness adjustment, equipped with cooling fan Reflected: Kohler illumination with adjustable aperture diaphragm, white LED light source, stepless brightness adjustment, equipped with cooling fan Control unit: Power switch (main switch), AC power supply input connector (100 to 240V)					
	Halogen	Transmitted: Telecentric, built-in aperture diaphragm, 12V/50W halogen lamp, stepless brightness adjustment, with cooling fan Reflected: BF/BD Kohler illumination with adjustable aperture diaphragm, 12V100W or 12V15W halogen lamp (selectable), external fiber illumination, stepless brightness adjustment Control unit: Power switch (main switch), AC power supply input connector (100 to 240 V)					
Illumination filter		One GIF filter is provided as standard (and mountable for both transmitted and reflected illumination)					
Stage	Measuring range	200×170mm	300×170mm	400×200mm	200×170mm	300×170mm	400×200mm
	Tabletop size	410×342mm	510×342mm	610×342mm	410×342mm	510×342mm	610×342mm
	Effective stage glass size	270×240mm	370×240mm	440×240mm	270×240mm	370×240mm	440×240mm
	Swiveling angle	±5°		±3°	±5°		±3°
Maximum table loading (glass top)		20kg		15kg	20kg		15kg
Measurement system		High-accuracy digital scale *2					
Measuring accuracy*2 (X and Y axes, when not loaded)		(2.2 + 0.02L)μm, L: measuring length (mm)					
Digital display	Minimum reading	1/0.5/0.1μm switchable					
	Display axes	X, Y and Z					
	Functions	Zero-setting, direction switching					
Remote BOX		Joystick (X and Y axes drive), lock button (X and Y axes), speed adjustment (X, Y and Z axes), coarse/fine adjustment button (X, Y and Z axes) Jog shuttle (Z axis drive), limit setting (Z axis), emergency stop switch, power source backup switch AF button (vision auto focus): effective when connecting to vision unit (optional) LAF button (laser auto focus): effective only for LAF models, just focus (JF), tracking focus (TF) Reset button (X, Y and X axes counter), data output button					
Laser auto focus (LAF)		—	—	—	○	○	○
Main unit dimensions (WxDxH)		632×892×782mm	632×892×782mm	757×907×782mm	608×790×846mm	658×790×846mm	733×790×846mm
Main unit mass		150kg	158kg	164kg	155kg	163kg	169kg
Dimensions for control unit for illumination unit (mm)		355×364×106.5mm					
Main unit mass		7kg					
Dimensions for control unit for illumination unit (WxDxH)		114×365×96mm					
Mass for control unit for illumination unit		LED: 3.5kg, halogen: 3.5kg					
Maximum power consumption		230W					

* To denote your AC line voltage add the following suffixes to the order No.: A for UL/CSA, D for CEE, E for BS, DC for China, K for EK, C for Taiwan, No suffix is required for JIS/100V

*1: Make sure that you use RS-232C cable (No. 12AAA807) to connect a LAF model and a power turret.

*2: Patent registered in Japan.

*3: Measured in conformance with JIS B 7153.

Optional Accessories System Diagrams

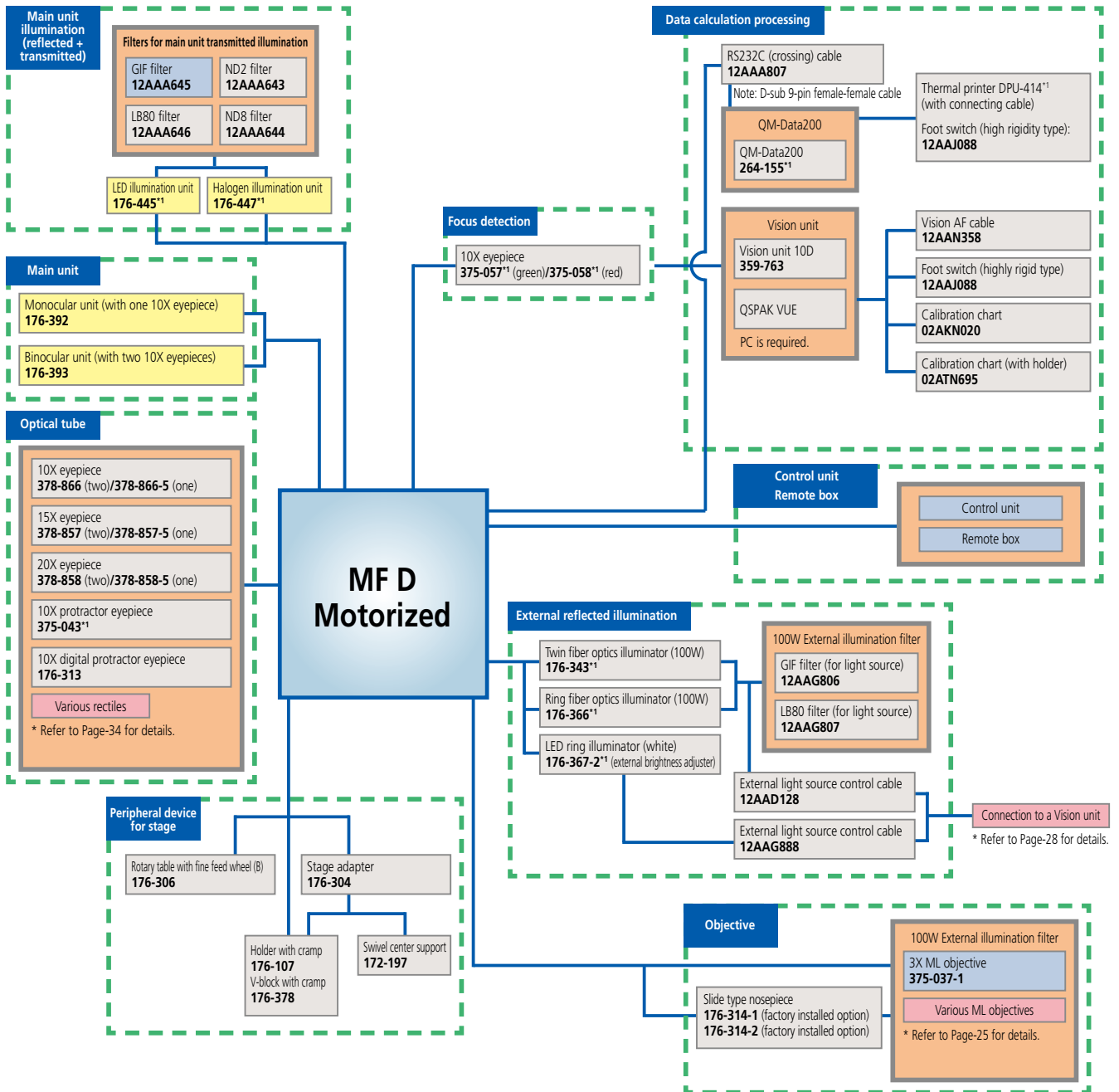

Printing of counter data

- Thermal printer DPU414^{*1} (with connecting cable)
- Foot switch (highly rigid type) 12AAJ088

Data management

- Real-time process control **MeasurLink**
- Inspection table creation program **MeasureReport**
- Note: A PC is required.
- RS232C (crossing) cable 12AAA807

Optional peripheral device

- Vibration damping stand 176-308
- Mounting stand (microscope + QM-Data 200) 176-309
- Lens cleaning set 12AAA165
- Vertical system rack (for Vision Unit) 998923
- Stage micrometer 375-056

*1 Order No. depends on the destination.

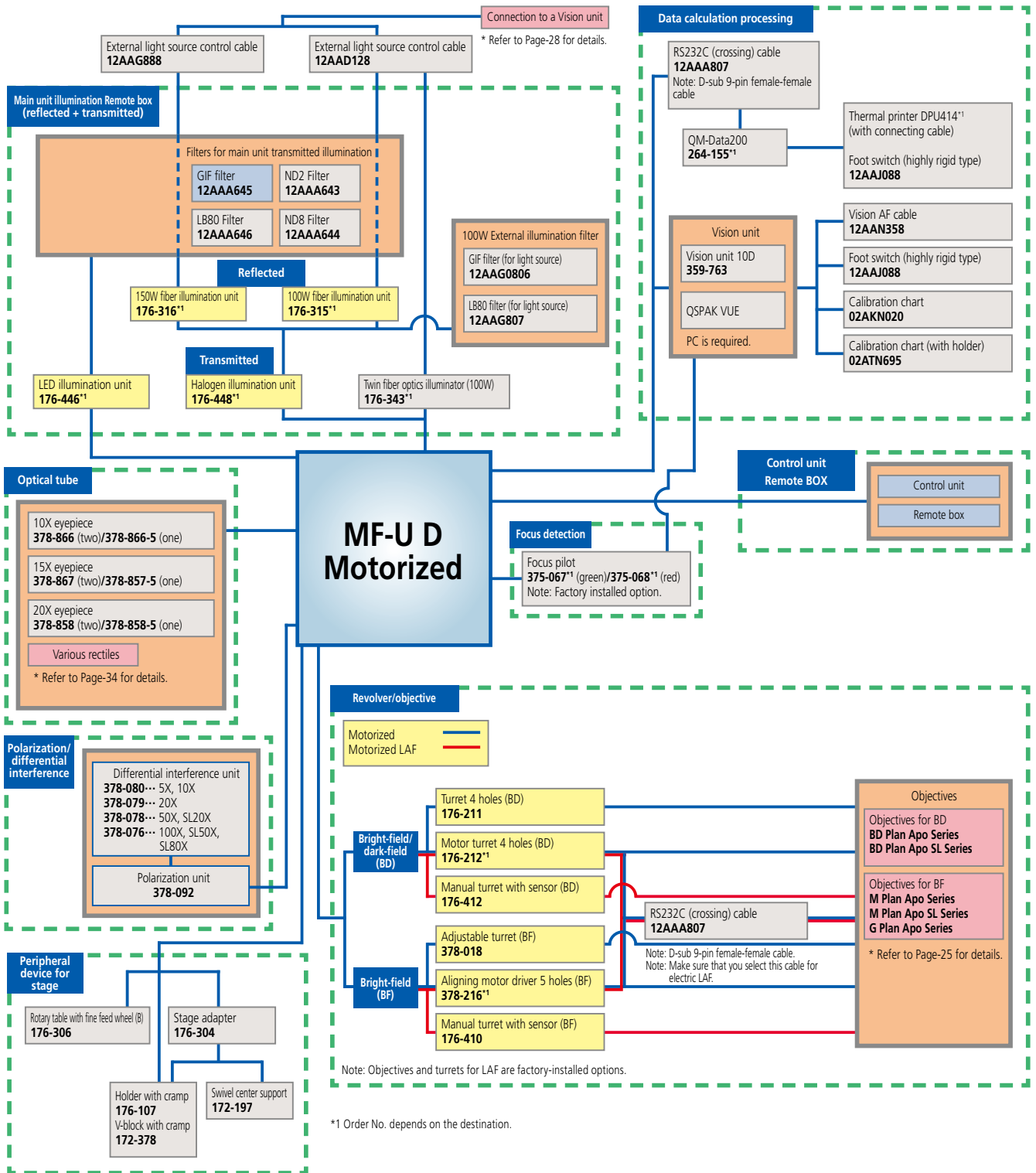

Refer to the corresponding page for details.

Required.

Standard accessory.

Optional Accessories

Lenses

Our eyepieces provide a wide field of view (with field number 24 when using 10X magnification) to enable easy observation and measurement of objects. The standard objectives provide a bright image with a long working distance and less flare. For both the bright-field and dark-field FS objectives, plan apochromat specifications are used. We think that being able to observe and measure objects without fatigue, even for long periods of time, is very important.

Eyepieces



Eyepieces			
	WF10X/24	WF15X/16	WF20X/12
Order No. (1 piece)	378-866-5	378-857-5	378-858-5
Order No. (2 pieces)	378-866	378-857	378-858
Magnification	10X	15X	20X
Field number	24	16	12
Applicable model	MF C / MF-U C / MF D / MF-U D		

- Only the 10X model includes the eye shade.
- If using a measuring microscope older than the MF B series with a binocular eyepiece, select Order No. **378-866**.

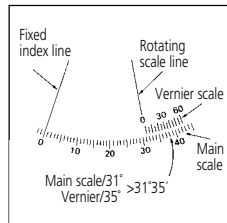

Protractor Eyepiece	
Order No.	375-043
Magnification	10X
Field number	21
Scale	360° 5'
Applicable model	MF C / MF D



Digital Protractor Eyepiece

Digital Protractor Eyepiece		
Order No.	176-313 ¹	
Eyepiece detector unit	Magnification	10X
	Field number	22
	Reticle	Line width: 5µm for both 90° solid lines and 45° chain lines
	Measuring range	Degrees: 0.00° to ± 369.99° Arc-minutes: 0° 00' to ± 369° 59'
	Detection method	Electrostatic capacitance encoder
Digital counter (standard equipment) Supports CE	External dimensions (mm)	ø120×140(D)
	Minimum reading	0.01° (degree) or 1' (arc-minute)
	Function	Zero-set ABS*/INC selection, degree or arc-minute selection, data output (with foot switch 12AAJ088)
	Output	RS-232C
	External dimensions (mm)	143(W)×112(D)×57(H)
	Power supply	AC100~120V
Applicable model	MF C / MF D (fixable to the top surface of the counter)	

*This measurement system does not always supply power to the internal scale to display absolute values. The system measures coordinates from any fixed origin.

*1 Order No. depends on the destination.

Optical Tubes



Monocular Tube	
Order No.	176-392
Magnification	10X
Field number	24
Applicable model	Required for MF C / MF D



Binocular Tube	
Order No.	176-393
Magnification	10X
Field number	24
Applicable model	Required for MF C / MF D



Tilting Binocular Tube	
Magnification	10X
Field number	24
Angle of column (tilt angle)	0~30°
Applicable model	Included in MF-U C / MF-U D as standard

For inspection or observation using a microscope, high resolution and an ultra-long working distance are important factors for objective usability. Also, using the apochromat specifications (for correction of the red, blue, and yellow wavelengths) to correct chromatic aberration over a wide range of wavelengths and the plan specifications to correct distortion in the image surface, and point aberrations, is also important for getting a clear image across the whole field of view. Mitutoyo's high quality FS objectives have these characteristics, which expands the range of applications for a microscope and greatly improves its usability. These objectives are also helpful when installed in a measuring microscope. The M Plan Apo series and BD Plan Apo series are provided for bright-field observation. The SL (super long) specifications are available for when a long working distance is required. The G Plan Apo series is available corrected for observation through glass of thickness 3.5mm (or 2 to 5mm to special order).

ML objectives

Limited-correction optical system ... For **MF C / MF D**



Model No.	Order No.	Magnification	Numerical Aperture (N.A.)	Working Distance (mm)
ML 1X	375-036-2	1X	0.03	61.0
ML 3X	375-037-1	3X	0.09	77.0
ML 5X	375-034-1	5X	0.13	61.0
ML 10X	375-039	10X	0.21	51.0
ML 20X	375-051	20X	0.42	20.0
ML 50X	375-052	50X	0.55	13.0
ML 100X	375-053	100X	0.70	6.0

FS objectives

Infinity corrected optical system ... For **MF-U C / MF-U D**
For bright-field (**BF**) observation and measurement



Model No.	Order No.	Magnification	N.A.	Working Distance (mm)
M Plan Apo 1X	378-800-3	1X	0.025	11.0
M Plan Apo 2X	378-801-3	2X	0.055	34.0
M Plan Apo 5X	378-802-6	5X	0.14	34.0
M Plan Apo 7.5X	378-807-3	7.5X	0.21	35.0
M Plan Apo 10X	378-803-3	10X	0.28	33.5
M Plan Apo 20X	378-804-3	20X	0.42	20.0
M Plan Apo 50X	378-805-3	50X	0.55	13.0
M Plan Apo 100X	378-806-3	100X	0.70	6.0
M Plan Apo SL 20X	378-810-3	20X	0.28	30.5
M Plan Apo SL 50X	378-811-3	50X	0.42	20.5
M Plan Apo SL 80X	378-812-3	80X	0.55	15.0
M Plan Apo SL 100X	378-813-3	100X	0.70	13.0
M Plan Apo SL 200X	378-816-3	200X	0.62	13.0
M Plan Apo HR 50X	378-814-4	50X	0.75	5.2
M Plan Apo HR 100X	378-815-4	100X	0.90	1.3
G Plan Apo 20X (t3.5)	378-847	20X	0.28	Air conversion: 29.42
G Plan Apo 50X (t3.5)	378-848-3	50X	0.50	Air conversion: 13.89
Lens set B1	378-911	A set including M plan Apo 10X, 20X, 50X, and 100X		
Lens set B2	378-912	A set including M plan Apo 2X, 5X and SL20X		
Lens set B3	378-913	A set including M plan Apo 5X, 10X, 20X, and 50X		
Replacement adapter for FS objective	378-026-1	Used when a bright-field (BF) lens is attached to a bright-field and dark-field (BD) turret		

For observation and measurement using a bright-field or dark-field (**BD**)



Model No.	Order No.	Magnification	N.A.	Working Distance (mm)
BD Plan Apo 2X	378-831-7	2X	0.055	34.0
BD Plan Apo 5X	378-832-7	5X	0.14	34.0
BD Plan Apo 7.5X	378-830-7	7.5X	0.21	34.0
BD Plan Apo 10X	378-833-7	10X	0.28	33.5
BD Plan Apo 20X	378-834-7	20X	0.42	20.0
BD Plan Apo 50X	378-835-7	50X	0.55	13.0
BD Plan Apo 100X	378-836-7	100X	0.70	6.0
BD Plan Apo SL 20X	378-840-7	20X	0.28	30.5
BD Plan Apo SL 50X	378-841-7	50X	0.42	20.0
BD Plan Apo SL 80X	378-842-7	80X	0.50	13.0
BD Plan Apo SL 100X	378-843-7	100X	0.55	13.0
BD Plan Apo HR 50X	378-845	50X	0.75	5.2
BD Plan Apo HR 100X	378-846	100X	0.90	1.3
Lens set D1	378-931	A set including BD plan Apo 10X, 20X, 50X, and 100X		
Lens set D2	378-932	A set including BD plan Apo 2X, 5X, and SL20X		
Lens set D3	378-933	A set including BD plan Apo 5X, 10X, 20X, and 50X		

* Refer to Catalog No. E4191 "MICROSCOPE UNITS AND OBJECTIVES" for details.

Optional Accessories Illumination

How illumination (a light source) is used is important for observing and measuring various inspected objects such as semiconductors, electronic or electric components, automobile precision components, resin moldings, tools, medical products, and printed materials with clarity and high contrast. Select the best illumination according to the shape, surface conditions, color, and materials in the inspected object.

A: Reflected illumination and transmitted illumination (required)



①

LED Illumination Unit

Order No.	176-345 (MF C) /176-445(MF D)
	Made up of lamp housing (for reflected illumination and transmitted illumination) and an LED control unit. The LED control unit can be fixed to the rear of the column of the microscope main unit. White light LED (low power consumption: 65W) Rated life of approximately 30,000 hours continuously variable brightness control Built-in cooling fan (includes an alarm for indicating that the fan has stopped) A color filter can be attached to a reflected or transmitted illumination unit.
External dimensions (mm)	Reflected illumination unit: $\phi 33 \times 86$ (maximum protrusion) Transmitted illumination unit: 68×103 (maximum protrusion) LED control unit: $118(W) \times 365(D) \times 96(H)$
Applicable model	MF C/MF D

* To denote your AC line voltage add the following suffixes to the order No. (e.g.: **176-345A**): **A** for UL/CSA, **D** for CEE, **E** for BS, **DC** for China, **K** for EK, **C** for Taiwan, No suffix is required for JIS/100V



③

LED Illumination Unit

Order No.	176-346 (MF UC) /176-446(MF UD)
	Made up of lamp housing (for reflected illumination and transmitted illumination) and an LED control unit. The LED control unit can be fixed to the rear of the column of microscope main unit. White light LED (low power consumption: 70W) Rated life: Approximately 30,000 hours Continuously variable brightness control Built-in cooling fan (includes an alarm for indicating that the fan has stopped) A color filter can be attached to a reflected or transmitted illumination unit.
External dimensions (mm)	Reflected illumination unit: 68×66 (maximum protrusion) Transmitted illumination unit: 68×103 (maximum protrusion) LED control unit: $118(W) \times 365(D) \times 96(H)$
Applicable model	MF-U C/MF-U D

* To denote your AC line voltage add the following suffixes to the order No. (e.g.: **176-346A**): **A** for UL/CSA, **D** for CEE, **E** for BS, **DC** for China, **K** for EK, **C** for Taiwan, No suffix is required for JIS/100V

MF series

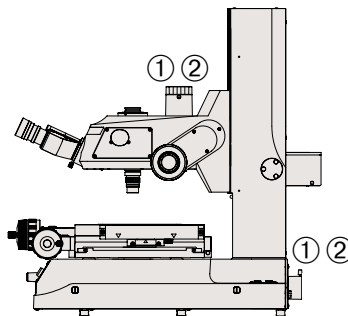

MF-U series

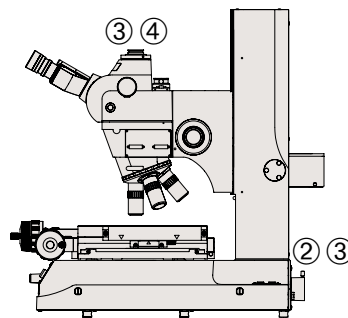

②

Halogen Illumination Unit

Order No.	176-347 (MF C)/176-348 (MF-U C) /176-447 (MF D)/176-448 (MF-U D)
	Made up of lamp housing (for reflected illumination and transmitted illumination) and a halogen control unit. The halogen control unit can be fixed to the rear of the column of the microscope main unit. 12V, 50W halogen lamp, continuously variable brightness control Built-in cooling fan (includes an alarm for indicating that the fan has stopped) A color filter can be attached.
External dimensions (mm)	Reflected and transmitted illumination unit: 91×106 (maximum protrusion) Halogen control unit: $118(W) \times 365(D) \times 96(H)$
Applicable model	MF C/MF-U C/MF D/MF-U D

Note: MF-U C is available only for transmitted illumination.

* To denote your AC line voltage add the following suffixes to the order No. (e.g.: **176-347A**): **A** for UL/CSA, **D** for CEE, **E** for BS, **DC** for China, **K** for EK, **C** for Taiwan, No suffix is required for JIS/100V



④

100W and 150W Fiber Optics Cable Illumination Unit (External Light Source)

Order No.	176-315* (100W) ·176-316* (150W)
100W	12V, 100W halogen lamp (No. 517181) Rated life: 1,000 hours 12V, 100W high brightness halogen lamp (No. 12BAD602) Rated life: 50 hours Continuously variable brightness control
External dimensions (mm)	$76(W) \times 235(D) \times 120(H)$, Fiberglass cable length: 1,500
150W	15V, 150W halogen lamp (No. 12BAJ076) Rated life: 500 hours 15V, 150W high brightness halogen lamp (No. 12BAJ075) Rated life: 50 hours Continuously variable brightness control
External dimensions (mm)	$120(W) \times 273(D) \times 119(H)$, Fiberglass cable length: 1,500
Applicable model	For reflected illumination when selecting the halogen illumination unit with MF-U C / MF-U D

* Order No. depends on the destination.



B Dual swan-neck light pipe (External Light Source)	
Order No.	176-343*
	Fixed to the rear of the microscope column. Continuously variable brightness control Includes a condenser lens Auto-brightness control can be used for the Vision Unit system (with external light source control cable No. 12AAD128). 12V, 100W halogen lamp (No. 517181), rated life: 1,000 hours 12V, 100W high brightness halogen lamp (No. 12BAD602), rated life: 50 hours LB80 filter (No. 12AAG807)
External dimensions (mm)	76(W)×235(D)×120(H): includes only the light source Fiber optics cable length: 700 (from the rear fixed portion to the front edge) Maximum fiber bending radius: 60
Applicable model	MF C / MF-U C / MF D / MF-U D

C Fiber-Optic Ring Light (External Light Source)	
Order No.	176-366*
	Continuously variable brightness control Includes a condenser lens Auto-brightness control can be used for the Vision Unit system (with external light source control cable No. 12AAD128). 12V, 100W halogen lamp (No. 517181) Rated life: 1,000 hours 12V, 100W high brightness halogen lamp (No. 12BAD602) Rated life: 50 hours LB80 filter (No. 12AAG807)
External dimensions (mm)	76(W)×235(D)×120(H): includes only the light source Circular illumination unit: outside diameter: 60, inside diameter: 35 Maximum fiber length: 1,000
Applicable model	MF C / MF D (ML objective 10X or lower model)

* Order No. depends on the destination.

* Order No. depends on the destination.

A: Reflected and Transmitted Illumination

The light is projected vertically downward onto the surface of an inspected object through an objective. An LED or halogen lamp is selectable as the light source.

Image

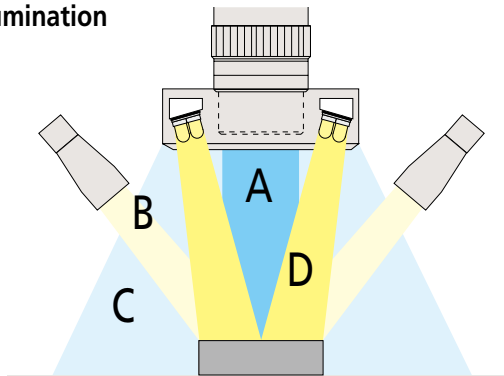

The four images show the same portion of an inspected object.

C: Fiber-Optic Ring Light

Light piped from a standalone halogen lamp unit and projected from around the objective enables observation that is less affected by shadows due to surface irregularities and is suitable for image measurement.



Image

B: Dual swan-neck light pipe

Light piped from a standalone halogen lamp unit and projected from two heads is suitable for three-dimensional observation. The condenser lens included as standard makes high brightness spot lighting possible.

Image



Image

D: LED Ring Light

Light from an LED array surrounding the objective enables high contrast observation of deeply colored resins, circuit boards, and small cylindrical objects and is also suitable for image measurement. In addition, adjusting the brightness does not change the coloring.



Image



D LED Ring Light	
Order No.	176-367-2*
	Continuously variable brightness control Auto-brightness control can be used for the Vision Unit system (with external light source control cable No. 12AAG888).
External dimensions (mm)	75(W)×150(D)×90(H): only the control part Ring LED part: outside diameter: 70, height: 68 to 93 LED cable length: 1,500
Applicable model	MF C / MF D (ML objective 10X or lower model)

* Order No. depends on the destination.

D LED Ring Light (for FS Objectives)	
Order No.	Please contact us.
	Fixed to an objective and projects ring-shaped white LED light Continuously variable brightness control Auto-brightness control can be used for the Vision Unit system (with external light source control cable No. 12AAG888).
External dimensions (mm)	75(W)×150(D)×90(H): only the control part Ring LED part: outside diameter: 70, height: 65 to 80 LED cable length: 1,000
Applicable model	MF-U C / MF-U D (FS objective M plan Pro 10X or lower model)

Manual Image Measurement Vision Unit

The Vision Unit turns your measuring microscope into a high-performance vision measuring system capable of significantly increasing productivity in quality assurance operations. Vision measurement simply involves generating enough points from the edges of workpiece features to ensure accuracy and then letting powerful PC-based software calculate the measurement results. An image measuring model that aligns edges during image measurement and a dedicated electronic model that can be used for general purposes are available. Both models can print out the measurement results or output them to spreadsheet software or inspection tables.



Typical system

For details, see Catalog No. E14008

Features

- Auto edge detection tool and various macro icons make measurement straightforward
- Easy-to-use graphics and measurement navigation
- Enables measurement results to be output to MS-Excel*1 and an inspection table created on the same PC
- Enables tolerance zone analysis for measurement and calculation results, and various types of statistical processing for each item
- Auto-brightness control that precisely duplicates an illumination setting (when using the measuring microscopes MF C, MF-U C, MF-D and MF-UD together)
- Enables high-accuracy height measurement when combined with the focus pilot
- Enables measurement within one screen
- Images can be input or saved (in BMP or JPEG format).

*1. MS-Excel is a Microsoft product.

More user-friendly manual measurement environments available (Wide-field measurement)

Upsizing of the image sensor has made the field of view approximately 40% wider than conventional for both X and Y directions, thus allowing concurrent observation of the circumference of a measurement point.

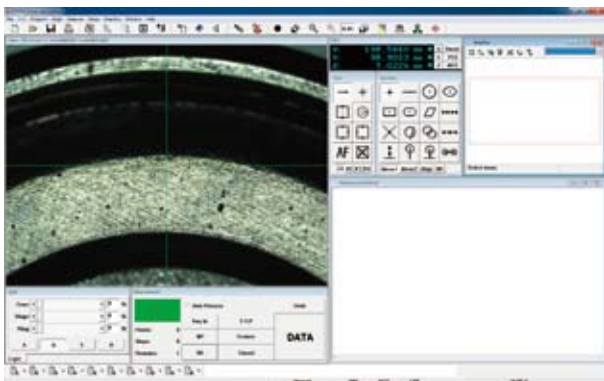

* An actual image using objective lens ML1X plus LED ring light

Edge detection support tools (One-click tools)

[Patent registered (application country: Japan)]

Each tool has the function of automatically discriminating operations from self tool setup to edge detection/calculation by merely single-clicking the vicinity of a measurement point edge with the mouse. If measurement is performed in one tool window, these tools drastically reduce measurement time thanks to no need for stage travel.

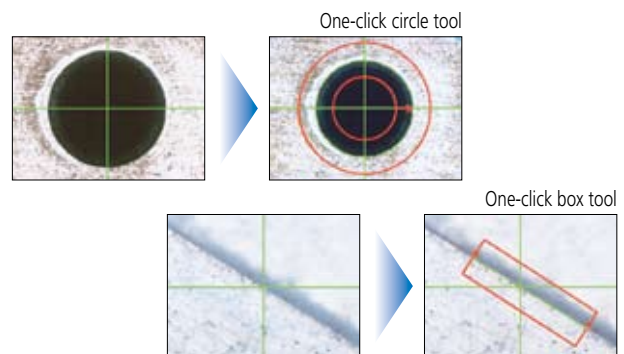

Coordinate system creation key

Coordinate system



Creation key1

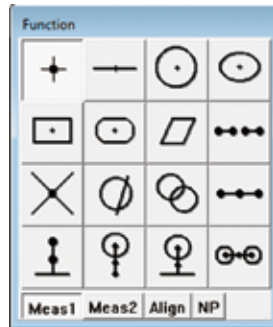

Creation key2



Coordinate value input formatting function (NP measurement)

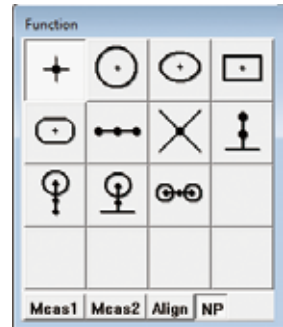

Specifications

Vision Unit	
Order No.	MF C: No. 359-796 (Vision Unit 9C) / MF-UC: No. 359-798 (Vision Unit 9UC) / MF D & MF-UD: 359-763 (Vision Unit 10D)
Magnification of optical system	0.5X: when a microscope is attached (0.5X: when using a TV adapter)
Image detection	High sensitivity 1/2-inch CMOS color camera with 300 million pixels
Resolution	0.1μm
Measuring accuracy for each axis (in a 20°C environment)	Depends on measuring microscope
Accuracy (in a 20°C environment)	Depends on measuring microscope Reference: when using a 3X ML objective (performing an inspection using our standard sample) Screen-internal measuring accuracy: ±2.5μm or less Screen-internal repeatability (2σ): ±1μm or less
PC system*	Windows 7
Software*	QSPAK Vision Unit
Applicable model	MF C / MF-U C / MF D / MF-U D

* Software (QSPAK) and calculation processor are required separately.

FORMPAK-QV (Optional software)

FORMPAK-QV allows contour analysis and contour tolerancing against the nominal value, from the data acquired using QSPAK.

- Contour tolerancing function
- Fine contour analysis function
- Report generation function

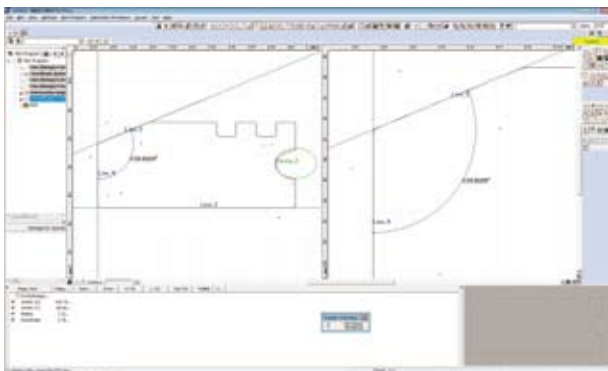

CAD Import & Export (Optional software)

Operability has been greatly improved, and the time required to create a part program has been greatly reduced, by importing the CAD data (DXF, IGES), as generated at the product-design stage, to QSPAK. The measurement result from QSPAK can be converted to CAD data.

FEATURES

- The nominal value of each measuring item is entered automatically.
- The graphics window can be used to calculate elements.
- Graphics data can be output in a specified CAD data format.

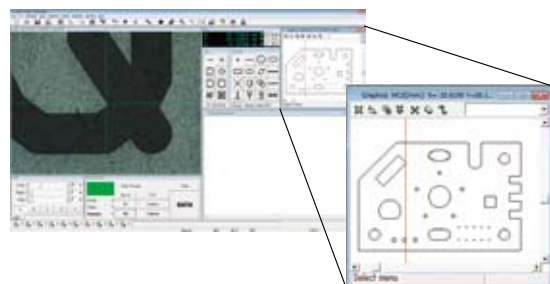

2-D Data Processing Unit

QM-Data 200



Typical system



Foot switch No. 12AAJ088

Features

- Displays high contrast color graphics on a large, backlit, LCD screen
- Enables frequently-performed complex measurement (such as measuring the distance between two circles) to be performed by pressing just one button
- Teaching function for measuring procedure
- Efficient measurement by performing measuring point navigation in the repeat mode
- Eliminates the need to switch measuring command keys through AI-based measurement (which automatically determines the measured element)
- Includes a user menu in which you can individually register measuring commands or part programs
- Enables tolerance zone measurement for measurement and calculation results, and various types of statistical processing for each item
- Enables measurement results to be output to the MS-Excel*1 PC spreadsheet software in CSV format
- Enables part programs and measurement results to be stored in USB memory*2 or on a USB-FDD (floppy disk)
- A stand that can be tilted to adjust the angle to an easily viewable position
- Enables measurement during printing

*1. MS-Excel is a Microsoft product.

*2. Not all commercially available USB memory is supported.

Specifications

QM-DATA 200 (Stand Type)	
Order No.	264-155*
Displayed language	Switched among 16 languages (Japanese, English, French, German, Italian, Spanish, Portuguese, Czech, Chinese (traditional), Chinese (simplified), Korean, Turkish, Swedish, Polish, Dutch and Hungarian)
Unit of measurement	Length: mm, angle: degree/degree-minute-second (switchable)
Resolution	0.1µm
Program function	Creating, performing, and editing measuring procedures
Statistical processing	The measured item, number of data items, maximum value, minimum value, average value, standard deviation, range, histogram, and statistics for each measuring function (statistics for each command)
Display field	Color TFT LCD (with a backlight)
Tilt feature	Available
I/O connector	XYZ: for linear scale input ... up to 3 axes RS-232C (D): for connecting a PC (measuring result) RS-232C (2): for connecting the counter of the measuring machine main unit FS: for connecting a foot switch PRINTER: for connecting a receipt or external printer (measuring result) USB-FDD: for connecting a USB-FDD (measuring result file, measuring procedure file) USB-MEMORY: for connecting USB memory (measuring result file, measuring procedure file)
File output of measuring result	RS-232C output (CSV format, MUX-10 format)
Power supply	100V to 240V AC
Maximum power consumption	17W (without including options)
External dimensions (mm)	Approximately 260×242×310mm (including a stand)
Weight	Approximately 2.9kg
Applicable model	MF C / MF-U C / MF D / MF-U D

* Order No. depends on the destination.

External dimensions (unit: mm)

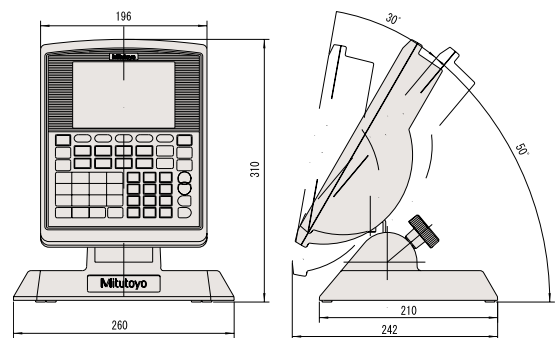

Thermal printer

DPU-414

Manufactured by SII



Specifications

Thermal Printer DPU-414		
Order No.	Connected to QM-Data 200	Please contact with your local Mitutoyo sales office.
	Counter display printing	Please contact with your local Mitutoyo sales office. Note: Combined use with footswitch No. 12AAA846
Printing method	Dot-matrix thermosensitive	
Number of printing digits	40 digits (9 normal characters (7 dot matrix))	
Printing speed	Maximum 52.5 normal characters/s	
External dimensions	160mm(W)×170mm(D)×65.5mm(H) (printer)	
Standard accessories	Printer cable, printing paper (1 roll), AC adapter (for 100V)	
Spare goods	Printing paper (5 rolls)	No. 908353 (5 rolls)

Printout example





```

Printer: SII-OFF
Contents to Be Printed: All Results w
Command Names
Point
M0001
X = 1.002 Y = 2.002
Circle
M0002
X = 1.999 Y = 2.001
D = 2.000 F2 = 0.002
Circle-Point Distance
M1.2
M0003
LC = 0.997 LL = 1.997
LS = 0.003 RS = 0.997
VD = -0.001
Start Pitch Measurement
Pitch
M0004
LC = 1.006 XD = 1.006
VD = 0.005 YD = 18.2506
    
```

Other Optional Accessories

We offer various optional accessories designed to increase microscope usability. These optional accessories, which have all been well received by customers, include the focus pilot, which can reduce focal point variation; a power turret and power focusing unit, which can be used to change the focus or magnification by under precise power control and a rotary table, which has a fine-adjustment knob for comfortably rotating objects under inspection. You can also select the polarization and differential interference contrast unit to support microscopic observation, the TV port adapter to attach a camera, which is required by many people during simultaneous analysis and evaluation, and other optional accessories as required.



Focus Detection Unit		Focus Pilot	
Model type	FP-05	FP-05U	
Order No.	375-057* (Green) / 375-058* (Red)	375-067* (Green) / 375-068* (Red)	
Light Source	Green LED or Red LED		
	<ul style="list-style-type: none"> Concentric circle pattern  	<ul style="list-style-type: none"> Slit pattern  	
	<ul style="list-style-type: none"> The focal point is the position where the top and bottom of the pattern are aligned. The brightness can be adjusted according to the reflectivity of the surface. Observation with a wide field of view on a TV monitor using 5X optical magnification is available. 		
Focusing reproducibility	Approximately 1.5μm (when using a 20X lens) ... This is a reference value based on an inspection performed using our standard sample.		
Optical magnification	0.5X		
Magnification accuracy	± 0.1% (within 2/3 of the center of the field of view)		
Camera	Supports up to 2/3 inch		
TV adapter	Equipped with C-mount, centering or parfocal adjusting mechanism		
Power supply	100 to 240V AC, Maximum power approximately 10W		
External dimensions (mm)	Main unit: 131(H)		
	Console box: 90(W)×78(H)×178(D)		
Applicable model	MF C / MF D	MF-U C / MF-U D	

Note: The combination of MF-U and FP-05U is a factory-installed option.
* Order No. depends on the destination.

Slide Type Nose Pieces (Factory-installed Option)

Order No.	176-314-1 The lens mounted at the centering mechanism (standard) position and the lens mounted at the focal point adjusting mechanism position are parfocal. Note: The magnification of the lens mounted at the focal point adjusting mechanism position is not guaranteed.
Order No.	176-314-2 Magnification of the lens mounted at the centering mechanism (standard) position and that of the lens mounted at the focal point adjusting mechanism position are guaranteed. Note: The two lenses are not parfocal.
Applicable model	MF C / MF D



Note: An external light source is not available with this product.



Electric Focus Unit	
Order No.	Please contact with your local Mitutoyo sales office.
	Attached to the Z-axis handle on the left side of the microscope to allow fine focus adjustment by turning the electric jog dial by hand. By using a jog shuttle, the variable speed coarse feed focus can be changed in 7-levels.
Maximum feed	0.4μm
Maximum drive speed	3.2mm/s
Driving method	Stepping motor (jog shuttle/jog dial)
Power supply	100 to 240V AC. Maximum power consumption: approximately 20W
External dimensions (mm)	Main unit: ø69×99(L)
	Console box: 108(W)×72(H)×193(D)
Applicable model	MF C / MF-U C

Note: This unit is made to order.



Turrets					
Order No.	176-211	378-018	176-212*	378-016*	378-216*
Supported observation	For bright-field and dark-field (BD)	For bright-field (BF)	For bright-field and dark-field (BD)	For bright-field (BF)	For bright-field (BF)
Number of ways	4	4	4	4	5
Centering and parfocal mechanism	—	Standard fixed: 1 position Centering and parfocal: 3 positions	—	Standard fixed: 1 position Centering and parfocal: 3 positions	Standard fixed: 1 position Centering and parfocal: 4 positions
Driving method	Manual		Electric		
Power supply	—	—	100 to 240V AC		
External dimensions (mm)	—	ø110×51(H)	Turret: 164(W)×65(H)×137(D) Console box: 108(W)×72(H)×193(D)		
	Cable length: 3m				
Applicable model	Required for MF-U C / MF-U D				

* Order No. depends on the destination.

Other Optional Accessories

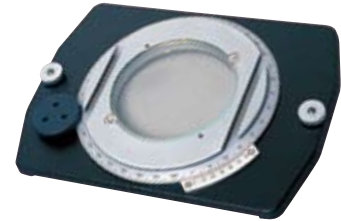

Rotary Table with Fine Feed Wheel (A)	
Order No.	176-305
External dimensions	280(W)×280(D)×23.7(H)mm Tabletop: ø240mm, 360° rotation, no angle scale
Mass	5.5kg
Effective glass diameter	182mm
Applicable model	Size 505, 10101, 2010 (MF C / MF-U C)

Note: The V-block with Clamp, Swivel Center Support and Holder with Clamp can be mounted on the table.

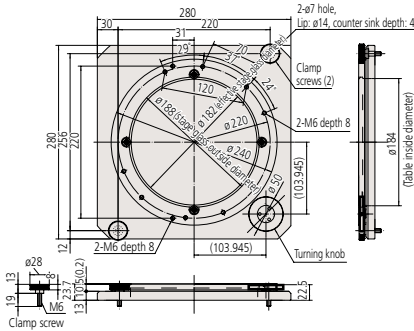

Rotary Table with Fine Feed Wheel (B)	
Order No.	176-306
External dimensions	342(W)×342(D)×23.2(H)mm Tabletop: ø270mm, 360° rotation, no angle scale
Mass	6.5kg
Effective glass diameter	238mm
Applicable model	Size 2017, 3017, 4020 (MF C / MF-U C / MF D / MF-U D)

Note: The V-block with Clamp, Swivel Center Support and Holder with Clamp can be mounted on the table.

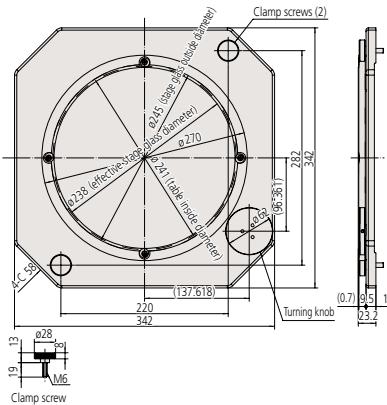

Rotary Table with Fine Feed Wheel (with Scale)	
Order No.	172-198
External dimensions	240(W)×172(D)×19.7(H)mm T-groove pitch of the tabletop: 120 Tabletop: ø270mm, 360° rotation, minimum angle adjustment: vernier 2'
Mass	2.4kg
Effective glass diameter	96mm
Applicable model	MF C / MF-U C Note: Size 2010 is used with stage adapter B Sizes 2017, 3017, and 4020 are used with stage adapter

Note: The V-block with Clamp, Swivel Center Support and Holder with Clamp can be mounted on the table.

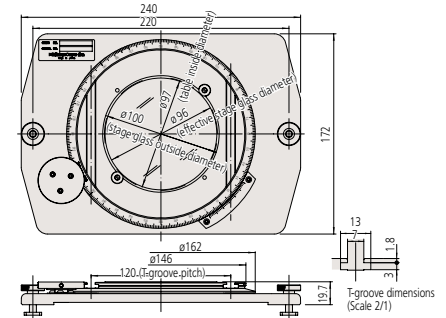

V-block with Clamp	
Order No.	172-378
External dimensions (mm)	117(H)×90(W)×45(D)
Mass	0.8kg
Applicable model	MF C / MF-U C / MF D / MF-U D Note: Size 2010 is used with stage adapter B. Sizes 2017, 3017, and 4020 are usable with stage adapter

Swivel Center Support	
Order No.	172-197
External dimensions (mm)	± 10° for swivel position Minimum angle index: 1° Suitable for measuring screws or other objects Maximum horizontal clamping size: ø80×140mm Maximum clamping size when inclined 10°: ø65×140mm
Mass	2.5kg
Applicable model	MF C / MF-U C / MF D / MF-U D Note: Size 2010 is used with stage adapter B. Sizes 2017, 3017, and 4020 are used with stage adapter

Holder with Clamp	
Order No.	176-107
Maximum clamp length (mm)	35
External dimensions (mm)	62(H)×152(W)×38(D)
Mass	0.4kg
Applicable model	MF C / MF-U C / MF D / MF-U D Note: Size 2010 is used with stage adapter B. Sizes 2017, 3017, and 4020 are usable with stage adapter

Stage Adapter / Stage Adapter B	
Order No.	176-304 (for 2017, 3017, 4020) B: 176-310 (for 2010)
External dimensions for one piece (mm)	50(W)×340(D)×15(H) Note: Adapter B is 280(D).
Mass	1.5kg / B: 1.2kg
Applicable model	MF C / MF-U C / MF D / MF-U D

Note: The two pieces are provided as one set.



Polarization Unit	
Order No.	378-092 (For both the bright-field model and the bright-field and dark-field model) Each polarizer/analyzer is provided as a one-piece set.
Applicable model	MF-U C / MF-U D

Differential Interference Contrast Unit	
Order No.	378-080 (for 5X and 10X) 378-079 (for 20X) 378-078 (for 50X and SL20X) 378-076 (for 100X, SL80X, and SL50)
Applicable model	MF-U C / MF-U D

Note: Use this with a polarization unit.

Illumination Filter		
For halogen illumination for a microscope*	GIF filter	12AAA645
	LB80 filter	12AAA646
	ND2 filter	12AAA643
For a light source of reflected illumination (for 100 W fiber illumination)	ND8 filter	12AAA644
	GIF filter	12AAG806
	LB80 filter	12AAG807

*MF C (for both transmitted illumination and reflected illumination), MF-U C (only for transmitted illumination)

Stage Micrometer	
Order No.	375-056
Scale length	1 mm
Minimum graduation	0.01mm
Scale accuracy (20°C)	1+L(μm). L: length between any two lines (mm)
Scale	Negative type / Positive type
External dimensions (mm)	76(W)×26(D)
Mass	16g
Applicable model	MF C/MF-U C/MF D/MF-U D

Note: After purchasing the product, we perform calibration. For details, contact a sales office near you.



C-Mount Adapter	
Order No.	970441
	This standard adapter is used to mount a device such as a digital camera to the TV camera port of a microscope. Note: This is not used when the Vision Unit is mounted.
External dimensions (mm)	∅45×22.5(H)
Applicable model	MF C / MF-U C / MF D / MF-U D



0.5X TV Adapter (Including C-Mount Adapter)	
Order No.	375-054
	This standard adapter is used to mount a device such as a digital camera to the TV camera port of a microscope. This adapter enables observation with a wide field of view using a 0.5X minimum relay image. Magnification accuracy: ±0.1%, Image field diameter: 11mm Note: This adapter is included with the Vision Unit as standard.
External dimensions (mm)	∅45×123(H)
Applicable model	MF C / MF-U C / MF D / MF-U D



Lens Cleaning Set	
Order No.	12AAA165
	This exclusive set includes cleaner, cloth, a blower, cotton wads, and other items for maintaining eyepieces and objectives.



Mounting Stand (for Microscope)	
Order No.	176-309
Maximum loading	300kg
External dimensions (mm)	1200(W)×900(D)×650(H)
Mass	Approximately 50kg
Applicable model	MF C / MF-U C / MF D / MF-U D

Note: When specifying a microscope with the Vision Unit or DV-520L, we recommend selecting the large mounting stand No. **960945**, which has external dimensions of 1,800(W)×900(D)×740(H).



Vibration Damping Stand	
Order No.	176-308
Supporting method	Spring pad
Maximum loading	200kg
External dimensions (mm)	750(W)×550(D)×36(H)
Mass	36kg
Applicable model	MF C / MF-U C / MF D / MF-U D

Other Optional Accessories

Reticles



For MF C / MF D

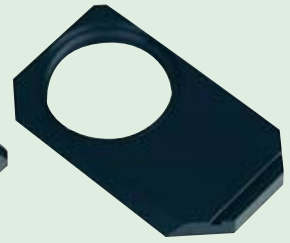

For MF-U C / MF-U D

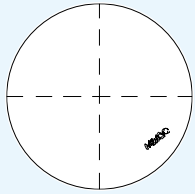

No.12AAG838 (MF C / MF D)
No.12AAG878 (MF-U C / MF-U D)
 90° chain lines
 Chain line pitch: 0.2 to 0.2
 Line width: 7µm

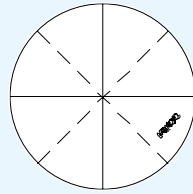

No.12AAG839 (MF C / MF D)
No.12AAG879 (MF-U C / MF-U D)
 90° solid lines, 45° chain lines
 Chain line pitch: 0.2 to 0.2
 Line width: 5µm

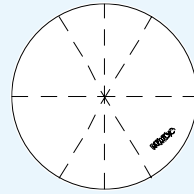

No.12AAG840 (MF C / MF D)
No.12AAG880 (MF-U C / MF-U D)
 90° chain lines, 60° chain lines
 Chain line pitch: 0.2 to 0.2
 Line width: 5µm

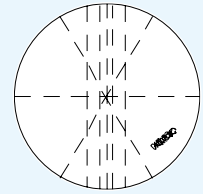

No.12AAG841 (MF C / MF D)
No.12AAG881 (MF-U C / MF-U D)
 Zeiss type pattern
 Chain line pitch: 0.2 to 0.2
 Line width: 5µm

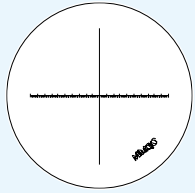

No.12AAG842 (MF C / MF D)*1
 Cross haired graduation lines
 0.1/20mm
 Line width: 7µm

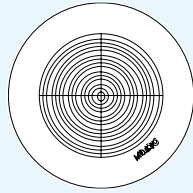

No.12AAG843 (MF C / MF D)*1
 Concentric circles with graduation lines
 ø1.2 to ø18
 Line width: 7µm

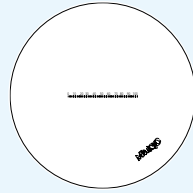

No.12AAG844 (MF C / MF D)*1
 Graduation lines
 0.1/10mm
 Line width: 10µm

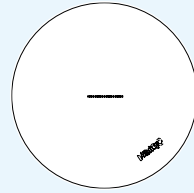

No.12AAG845 (MF C / MF D)*1
 Graduation lines
 0.05/5mm
 Line width: 10µm

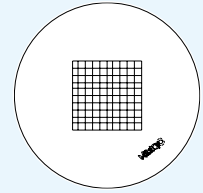

No.12AAG846 (MF C / MF D)*1
 Grid lines
 1mm 10mm
 Line width: 10µm

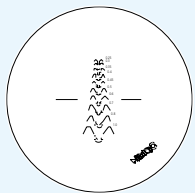

No.12AAG847 (MF C / MF D)*2
 Metric coarse screw thread
 p = 0.25 to 1.0
 Line width: 7µm

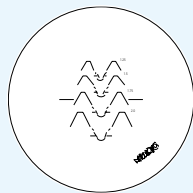

No.12AAG848 (MF C / MF D)*2
 Metric coarse screw thread
 p = 1.25 to 2.0
 Line width: 7µm



No.12AAG849 (MF C / MF D)*2
 Involute gear reference rack
 m = 0.1 to 1.0, pressure angle: 14.5°
 Line width: 7µm

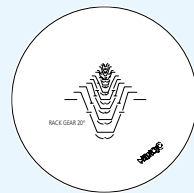

No.12AAG850 (MF C / MF D)*2
 Involute gear reference rack
 m = 0.1 to 1.0, pressure angle: 20°
 Line width: 7µm

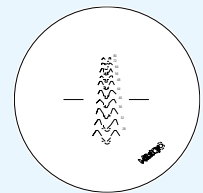

No.12AAG851 (MF C / MF D)*2
 Unified coarse screw thread
 80 to 28
 Line width: 7µm

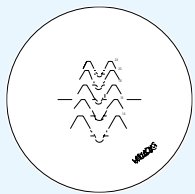

No.12AAG852 (MF C / MF D)*2
 Unified coarse screw thread
 24 to 14
 Line width: 7µm



No.12AAG853 (MF C / MF D)*2
 Unified coarse screw thread
 13 to 10
 Line width: 7µm

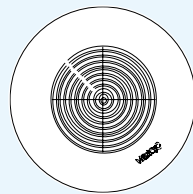

No.12AAG854 (MF C / MF D)*2
 Concentric circles with cross hairs
 0.01° to 0.20°
 Line width: 7µm

Reticle for digital protractor eyepiece
 (included as standard)

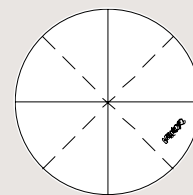

90° solid lines, 45° chain lines
 Chain line pitch: 0.2 to 0.2
 Line width: 7µm

Each reticle includes an attachment board.

*1. Use this with an eyepiece that has 10X magnification.

*2. This is the comparison chart specific to a 3X ML objective. Use this with an eyepiece that has 10X magnification.

External Dimensions

The LED illumination unit is included in the following figures.
 The control unit is placed to the side of the microscope or directly attached to the rear of the column.
 For the external dimensions for MF-D / MF-UD, please contact with your local Mitutoyo sales office.

MF C 1010

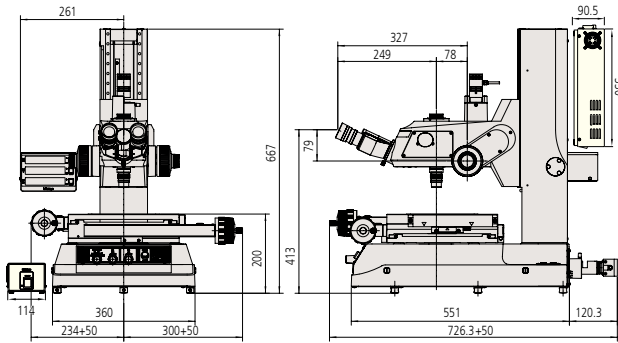

MF-U C 1010

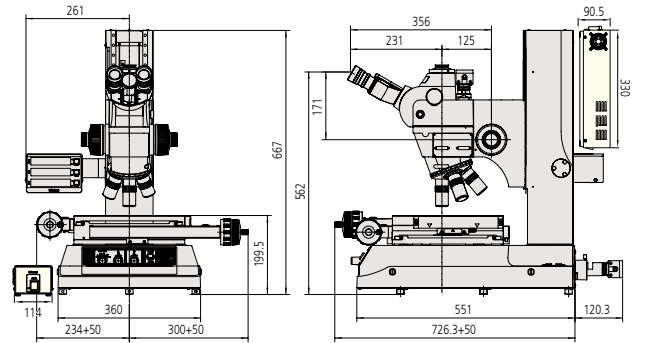

MF C 2010

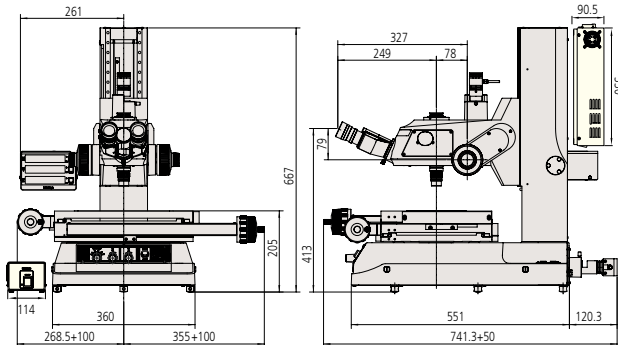

MF-U C 2010

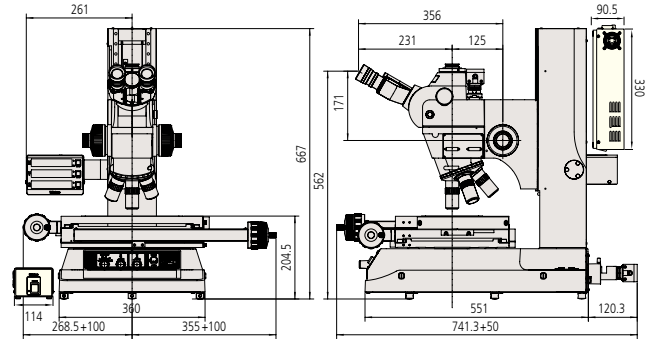

MF C 3017

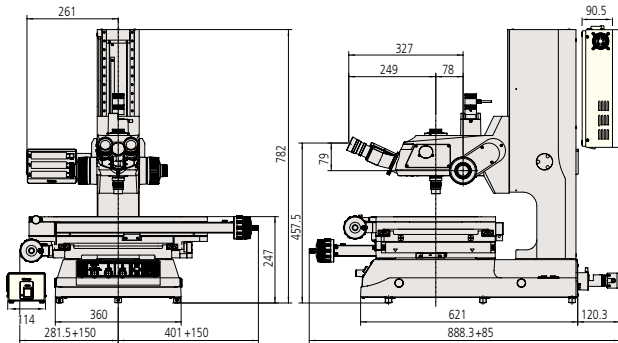

MF-U C 3017

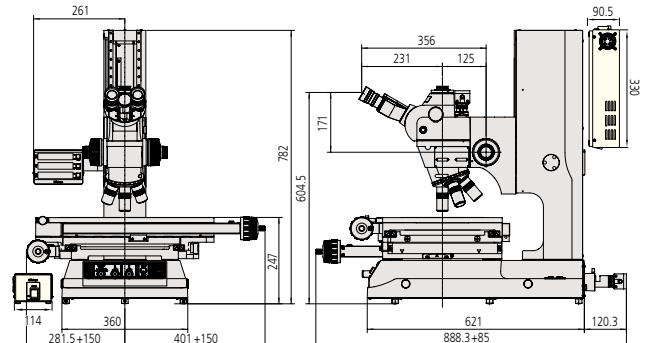

MF C 4020

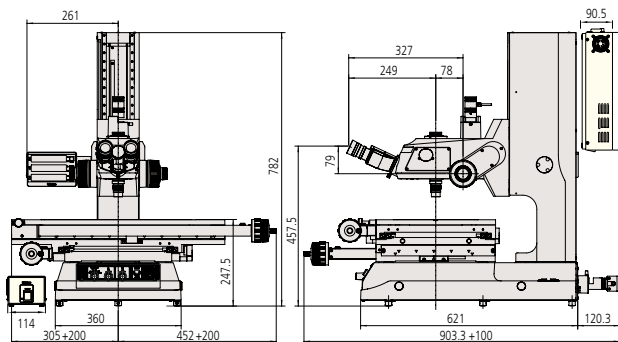

MF-U C 4020

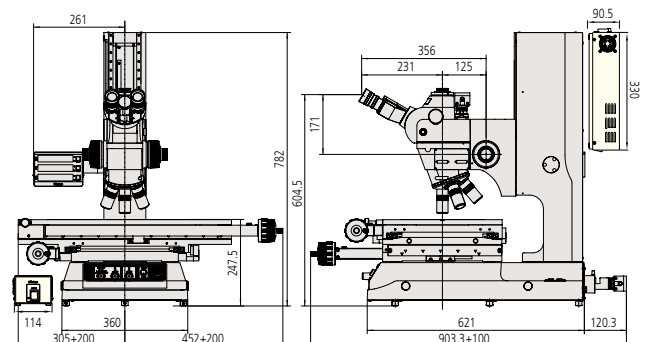



Note: All information regarding our products, and in particular the illustrations, drawings, dimensional and performance data contained in this pamphlet, as well as other technical data are to be regarded as approximate average values. We therefore reserve the right to make changes to the corresponding designs, dimensions and weights. The stated standards, similar technical regulations, descriptions and illustrations of the products were valid at the time of printing. Only quotations submitted by ourselves may be regarded as definitive.
Our products are classified as regulated items under Japanese Foreign Exchange and Foreign Trade Law. Please consult us in advance if you wish to export our products to any other country. If the purchased product is exported, even though it is not a regulated item (Catch-All controls item), the customer service available for that product may be affected. If you have any questions, please consult your local Mitutoyo sales office.

Export permission by the Japanese government may be required for exporting our products according to the Foreign Exchange and Foreign Trade Law. Please consult our sales office near you before you export our products or you offer technical information to a nonresident.

- Coordinate Measuring Machines
- Vision Measuring Systems
- Form Measurement
- Optical Measuring
- Sensor Systems
- Test Equipment and Seismometers
- Digital Scale and DRO Systems
- Small Tool Instruments and Data Management



Mitutoyo Corporation
20-1, Sakado 1-chome,
Takatsu-ku, Kawasaki-shi,
Kanagawa 213-8533, Japan
T +81 (0) 44 813-8230
F +81 (0) 44 813-8231
<http://www.mitutoyo.co.jp>

