



*Leica*  
MICROSYSTEMS

**Leica M125 C  
Leica M165 C  
Leica M205 C  
Leica M205 A  
User Manual**

# General Instructions

## Safety concept

Before using your microscope for the first time, please read the "Safety concept" booklet included with your instrument. It contains additional information about handling and care.



## Use in clean rooms

The Leica M series can be used in clean rooms without any problems.

## Cleaning

- Do not use any unsuitable cleaning agents, chemicals or techniques for cleaning.
- Never use chemicals to clean colored surfaces or accessories with rubberized parts. This could damage the surfaces, and specimens could be contaminated by abraded particles.
- In most cases, we can provide special solutions on request. Some products can be modified, and we can offer other accessories for use in clean rooms.

## Servicing

- Repairs may only be carried out by Leica Microsystems-trained service technicians. Only original Leica Microsystems spare parts may be used.

## Responsibilities of person in charge of instrument

- Ensure that the Leica stereo microscope is operated, maintained and repaired by authorized and trained personnel only.

# Safety Concept

The individual modules of the Leica M stereo microscopy series include an interactive CD-ROM with all relevant user manuals in 20 other languages. Keep it in a safe place, and readily accessible to the user. User manuals and updates are also available for you to download and print from our web site at [www.stereomicroscopy.com](http://www.stereomicroscopy.com).

This operating manual describes the special functions of the individual modules of the Leica M stereo microscopy series and contains important instructions for their operational safety, maintenance, and accessories.

The "Safety concept" booklet contains additional safety information regarding the service work, requirements and the handling of stereo microscope, accessories and electrical accessories as well as general safety instructions.

You can combine individual system articles with articles from external suppliers (e.g. cold light sources, etc.). Please read the user manual and the safety requirements of the supplier.

Before installing, operating or using the instruments, read the user manuals listed above. In particular, please observe all safety instructions.

To maintain the unit in its original condition and to ensure safe operation, the user must follow the instructions and warnings contained in these user manuals.

# Symbols Used

## Warning of a danger



This symbol indicates especially important information that must be read and complied with. Failure to comply can cause the following:

- Hazards to personnel
- Functional disturbances or damaged instruments

## Warning of hazardous electrical voltage



This symbol indicates especially important information that, if not observed, can cause the following:

- Hazards to personnel
- Functional disturbances or damaged instruments

## Danger due to hot surface



This symbol warns against touching hot surfaces, e.g. those of light bulbs.

## Important information



This symbol indicates additional information or explanations that intend to provide clarity.

## Action

- This symbol refers to actions described in the text that are to be carried out.

## Figures

- (1) Numbers in brackets within the descriptions relate to the figures and the items within those figures.

# Safety Instructions

## Description

The individual modules fulfill the highest requirements for observation and documentation of Leica stereo microscopes of the M series.

## Intended use

- Refer to "Safety Concept" booklet

## Non-intended use

- Refer to "Safety Concept" booklet

Never use M series microscopes or their components for surgical procedures (e.g. on the eye) unless they are specifically intended for that purpose.

The instruments and accessories described in this operating manual have been tested for safety and potential hazards. The responsible Leica affiliate must be consulted whenever the instrument is altered, modified or used in conjunction with non-Leica components that are outside of the scope of this manual.

Unauthorized alterations to the instrument or noncompliant use shall void all rights to any warranty claims.

## Place of use

- Refer to "Safety Concept" booklet
- Electrical components must be placed at least 10 cm away from the wall and from flammable substances.
- Avoid large temperature fluctuations, direct sunlight and vibrations. These conditions can distort measurements and micrographic images.
- In warm and warm-damp climatic zones, the individual components require special care in order to prevent the build-up of fungus.

## Responsibilities of person in charge of instrument

- Refer to "Safety Concept" booklet

Ensure that:

- The M series stereo microscopes and accessories are operated, maintained and repaired by authorized and trained personnel only.
- All operators have read, understood and observe this User Manual, and particularly the safety instructions.

# Safety Instructions (Continued)

## Repairs, service work

- Refer to "Safety Concept" booklet
- Only original Leica Microsystems spare parts may be used.
- Before opening the instruments, switch off the power and unplug the power cable.



Touching the live circuit can cause injury.

## Transport

- Use the original packaging for shipping or transporting the individual modules of the Leica M stereo microscopy series and the accessory components.
- In order to prevent damage from vibrations, disassemble all moving parts that (according to the user manual) can be assembled and disassembled by the customer and pack them separately.

## Integration in third-party products

- Refer to "Safety Concept" booklet

## Disposal

- Refer to "Safety Concept" booklet

## Legal requirements

- Refer to "Safety Concept" booklet

## EC Declaration of Conformity

- Refer to "Safety Concept" booklet

## Health risks



Workplaces with stereo microscopes facilitate and improve the viewing task, but they also impose high demands on the eyes and holding muscles of the user. Depending on the duration of uninterrupted work, asthenopia and musculoskeletal problems may occur. For

this reason, appropriate measures for reduction of the workload must be taken:

- Optimal arrangement of workplace, work assignments and work flow (changing tasks frequently).
- Thorough training of the personnel, giving consideration to ergonomic and organizational aspects.
- The ergonomic design and construction of the Leica M stereo microscopy series are intended to reduce the exertion of the user to a minimum.

## Safety Instructions (Continued)



Direct contact with eyepieces is a potential transmission method for bacterial and viral infections of the eye.

The risk can be kept to a minimum by using personal eyepieces for each individual or detachable eyecups.

### Light sources: Safety regulations

Protective measures of the manufacturer:

- UV protection screen in front of the specimen plane prevents the user from looking directly into the UV rays.
- Dummy filter carriers in the free positions of the rapid filter changer prevent direct UV radiation from reaching the eyes.
- UV filters are installed in the observation beam paths to protect the eyes.
- The stray-light protection on the lamp housing prevents irradiation of the hands.

### Warning



UV radiation could damage the eyes. Therefore:

- Never look into the light spot on the specimen plane without a UV protection screen.
- Never look into the eyepieces if no excitation filter is in the beam path.
- Do not select a white, strongly reflective background for the specimen.

## Safety Instructions (Continued)

### Supply unit

Always unplug the supply unit from the power supply:

- When installing and disassembling the lamp housing
- Before opening the lamp housing
- When replacing the high-pressure mercury lamp and other parts, such as the heat-absorbing filter or the collector
- During maintenance work on the supply unit

### Lamp housing



Never open the lamp housing while the lamp is switched on. Risk of explosion, UV exposure, blinding!



Before opening the lamp housing, allow it to cool off for at least 15 minutes. Danger of explosion!



Never cover the air duct on the lamp housing. Danger of fire!

### Mercury lamp

- Follow the user manual and safety instructions provided by the lamp manufacturer, and, in particular, the section on how to proceed if a lamp breaks and releases mercury.
- For transport, remove the mercury lamp, transport it in its original packaging and protect moving parts in the lamp housing using the transport anchors.
- When it has reached the end of its rated life (follow the manufacturer's specifications and the minute meter on the supply unit).
- To minimize the risk of explosion, replace a discolored mercury lamp promptly.
- Leica Microsystems assumes no liability for damage caused by exploding, incorrectly installed or improperly used mercury lamps.



# Contents

General Instructions	2
Safety Concept	3
Symbols Used	4
Safety Instructions	5

## The Leica M Series

Congratulations!	13
A Step Towards Infinity	14
The Electronics: Comfort, Convenience and Safety for Your Experiments	15
The Modular Design: Everything is Relative	16
Maximum Compatibility	17
On We Go	18

## Assembly

Base and Focusing Column	20
Optics Carrier	21
Tube	22
Eyepieces	23
Objective	24
Objective Nosepiece – Assembly	25
Objective Nosepiece – Adjusting Parfocality	26
AX Carrier – Preparation	27
AX Carrier – Assembly	28
Transmitted-light Base Leica TL ST	29

Transmitted-light Base Leica TL BFDF: Before First Use	30
Transmitted-light Base Leica TL BFDF	31
Leica TL RC / Leica TL RCI	32
Leica IsoPro Manual Cross-stage: Assembly	33
Leica IsoPro Motorized Cross-stage: Assembly	36
Cables: Terminals	40
Cables: Cable Duct	41
Cables: Diagram	42
Leica LED5000 MCI	43
Leica LED5000 MCI: Alternative Assembly	44
Leica LED5000 RL: Assembly	45
Leica LED5000 RL: Installing Optional Accessories	47
Leica LED5000 RL: Use	48
Leica LED5000 NVI: Assembly on High-Performance Stereo	
Microscopes (Leica M125 C / Leica M165 C / Leica M205 C)	50
Leica LED5000 NVI: Installing Optional Accessories	53

## Quick Start Guide

The Fastest Route to Success	56
Overview of an M Series Microscope	57
The Correct Interpupillary Distance	58
Using the Eyepieces	59
Focusing	60
Adjusting the Resistance of the Focus Drive	61

## Contents (Continued)

Changing the Magnification (Zoom)	62
Ratchet Steps and Magnification Levels	63
Parfocality: More Comfort and Convenience for Your Work	64
Iris Diaphragm	65

### Eyepieces

Magnification Factors of the Eyepieces	67
Health Notes	68
Dioptric Correction	69
Dioptric Correction and Parfocality	70
Graticules	71

### Photography & Video

Photography & Video	73
Photo Tubes and C-mounts	74
Trinocular Video/Phototube 50 %	75
Trinocular Video/Phototube 100 %	76

### Microscope Carrier

The Microscope Carrier AX	78
The Objective Nosepiece	80

### Objectives and Optical Accessories

The Different Types of Objectives	82
-----------------------------------	----

### Bases

Transmitted-light Base Leica TL ST: Controls	84
Transmitted-light Base Leica TL ST: Operation	85
Transmitted-light Base Leica TL ST: Lamp Replacement	86
Transmitted-light Base Leica TL BFDF: Controls	87
Transmitted-light Base Leica TL BFDF: Operation	88
Leica TL RC / Leica TL RCI: Controls	89
Leica TL RCI: The Deflection Mirror	90
Leica TL RCI: Color Intensity and Temperature	91
Leica TL RC / Leica TL RCI: Operation	92
Leica TL RCI: Methods in Transmitted Light	93
Leica TL RCI: Relief Images	94
Using Filters	96
Leica IsoPro (Non-motorized): Controls	97
Leica IsoPro (Motorized): Controls	98

### Accessories

Leica Hand Wheel and Foot Switch	100
Leica SmartTouch	101
Leica PSC Controller	102

## Contents (Continued)

### Dimensional Drawings

Leica M125 C / Leica M165 C	104
Leica M205 C	108
Leica LED5000 MCI	111
Leica LED5000 RL	112
Leica LED5000 NVI	113

### Specifications for the Bases

Transmitted-light Base Leica TL ST	115
Transmitted-light Base Leica TL BFDF	116
Leica TL RC / Leica TL RCI	117
Leica IsoPro Motorized XY Stage	118

### Appendix

Calculating the Total Magnification and Field of View Diameter	120
Care, Maintenance, Contact Persons	121



# The Leica M Series

# Congratulations!

Congratulations on obtaining your new Leica M series stereo microscope. We are convinced it will exceed your expectations, as never before have we applied our decades of experience in the areas of optics, mechanical engineering and ergonomics in such an uncompromising manner.

The M series embodies all the qualities you associate with the name Leica Microsystems: excellent objectives, high-quality engineering, and reliability. Furthermore, the modular design ensures that the M series adapts perfectly to your needs – no matter which accessories you require for your tasks.

Though the reliability and robustness of Leica stereo microscopes is legendary, like any high-tech product, the M series requires a certain degree of care and attention. Therefore, we recommend that you read this manual. It contains all the information you need regarding operation, safety and maintenance. Simply observing a few guidelines will ensure that even after years of intensive use, your stereo microscope will continue to work as smoothly and reliably as on the very first day.

We wish you the best of success in your work – after all, you are now equipped with the best tool!

# A Step Towards Infinity

Ever since their introduction by Horatio S. Greenough, stereo microscopes have worked according to the optical principles based primarily on Ernst Abbe's research. For over a century, ingenious optics designers and engineers have worked to push magnification, resolution and image fidelity to the limit permitted by optics.

In doing so, they have always been constrained by the interrelation between three factors: the higher a microscope's resolution, the lower the available working distance. If one increases the distance of the optical axes, the three-dimensional image seen by the observer becomes distorted – a sphere becomes an ellipse, a flat surface curves toward the observer.

## **Limits are made to be broken.**

The Leica M205 C is the world's first stereo microscope with a zoom range of 20.5:1. This accomplishment, however, was not enough for Leica's engineers. With the new FusionOptic in the M205 C, they have succeeded in going yet another step beyond previous limits. In addition to the increase in magnification, the resolution, too, has been increased to up to 1,050 lp/mm\*, which corresponds to a resolved structure size of 472 nm.

Of course, this performance increase benefits your everyday work. Set up your specimens on the microscope with comfortable freedom of movement and discover details in stereo microscopy that you could never see before.

\* Leica M205 C with 1.0× planapochromat and 10× eyepieces

# The Electronics: Comfort, Convenience and Safety for Your Experiments

Never before have electronics been used as extensively in a Leica series as in the new M series. Optics carrier, tripod, base and illuminator are all connected using electrical contacts – which provides a number of advantages.



*Contacts not only transmit data, but also supply the power.*

## Reliability for your experiments

Exact reproducibility of results is an increasingly common demand, particularly in research and development. The continuous encoding captures parameters such as the magnification, the illumination, the position of the iris

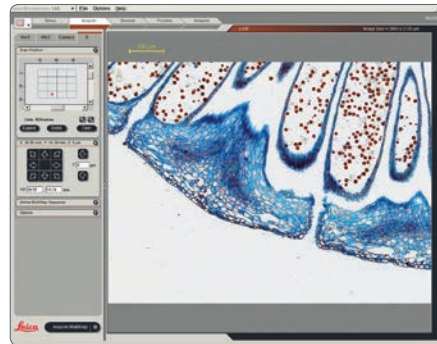

*Leica Application Suite (LAS) evaluates the transmitted data and can restore the test situation later.*

diaphragm and more to the Leica LAS software. Thus you always know the conditions under which an image was acquired.

## Fewer cables

A large part of the cables have been routed in the interior of the column. Data are also transferred via the interface between the column, the optics carrier and the carrier. The direct result is that you need fewer cables – this not only makes your workstation neater and more comfortable, it even makes it appear larger.

## The Modular Design: Everything is Relative

The Leica M series provides maximum flexibility in choosing equipment, thanks primarily to the modular configuration and the compatibility that Leica has painstakingly maintained for decades. The optics carriers, eyepieces, bases and more can be combined in any way you choose, allowing you to create the microscope that best suits your needs.

Despite this, you will notice that the controls and individual components do not differ significantly. Whichever configuration you choose, you will quickly feel right at home.

### **Have a special request? Let us know!**

Leica Microsystems enjoys an exceptional reputation when it comes to devising customer-specific solutions. If you have a special request that cannot be met with standard parts, contact your Leica consultant. We have a solution for every problem.

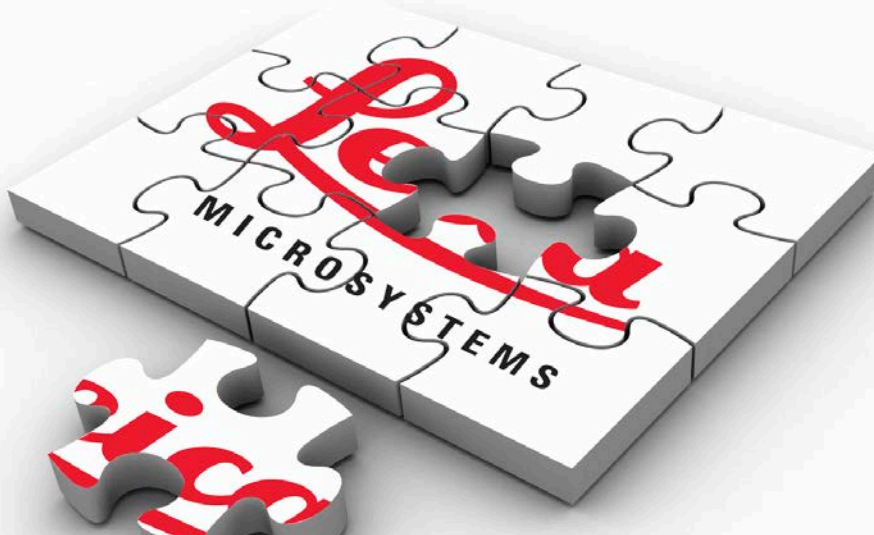



# Maximum Compatibility

Leica engineers were careful to ensure that the new M series – like its predecessors – remains compatible with existing series. This means that objectives, bases, tubes and so on can be reused.

## Objectives

All new objectives of the M series are parfocal, meaning that when used with the objective nosepiece, they can be replaced while keeping the specimen in perfect focus.

If you prefer, you can continue to use the previous objective series. In this case, parfocality is no longer guaranteed.

## Tubes

The interface between the optics carrier and the tube has remained the same, so existing tubes fit the new M series. The new tubes are designed for eyepieces with field number 23, while the predecessor models were only designed for field number 21, resulting in a smaller object field.

## Eyepieces

However, the new M-series eyepieces models have an audible and tangible click to provide immediate feedback in case of accidental adjustment.

## On We Go

If your new Leica microscope has already been assembled and commissioned by your Leica consultant, click [here](#) to skip through the installation instructions and go directly to the Quick Start Guide on [page 55](#).



If, on the other hand, you are assembling the microscope yourself, continue with the "Assembly" chapter, which begins on [page 19](#).

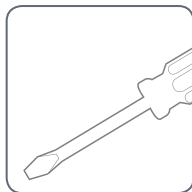

# Assembly

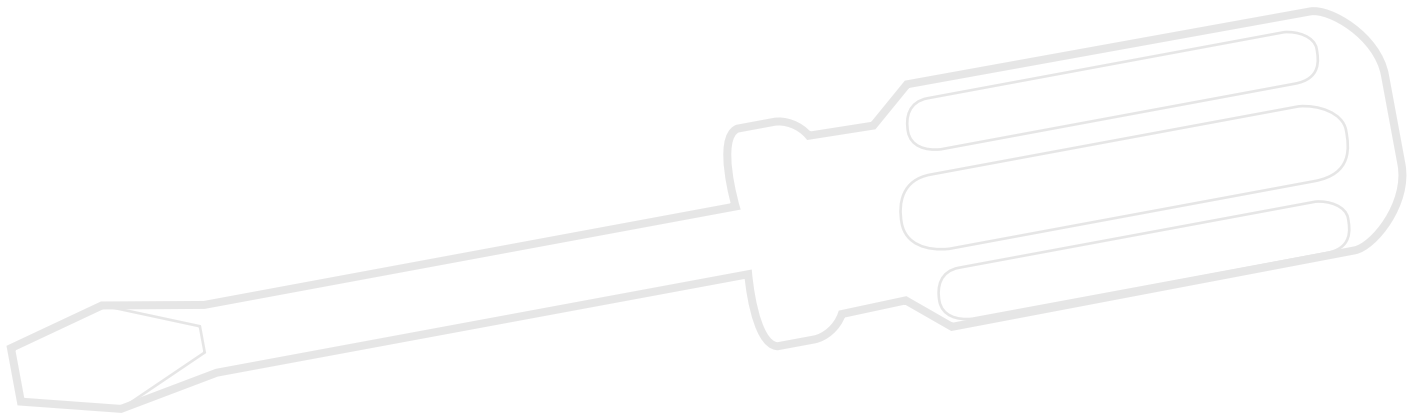

# Base and Focusing Column

The first step is to connect the focusing column of the M Series to the corresponding base.

## Tools used

- Hex socket screwdriver, 3 mm

## Assembling the column adapter

1. Securely install the column adapter on the column using the four included screws.

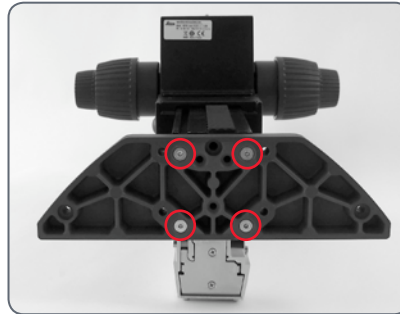

## Assembling the focusing drive

2. Securely screw the focusing column to the base using the six included screws.

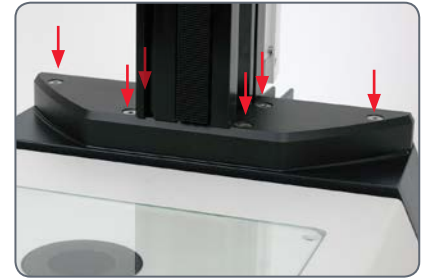

# Optics Carrier

## Tools used

- Hex socket screwdriver, 4 mm

## Assembling the optics carrier

1. Place the optics carrier on the focusing column so that the screw fit into the thread provided and the lug fits into the groove.
2. Press the optics carrier backwards to the focusing column and screw it in place using your other hand.

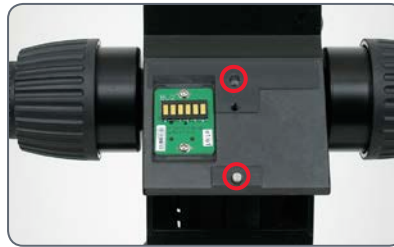

# Tube

All intermediate tubes that fit between the optics carrier and the binocular tube are fitted in the same manner.

## Tools used

- No tools required.

## Preparations

1. Unscrew the positioning screw and remove the protective cover.

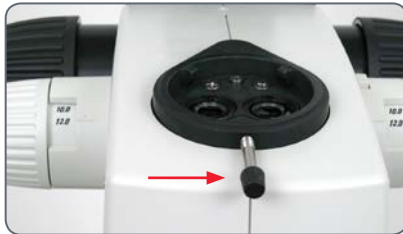

## Assembling the tube

2. Push the tube (for example, the inclined binocular tube) into the dovetail ring and rotate it slightly in both directions until the positioning screw meshes with the guide groove.
3. While holding the tube only slightly, carefully tighten the positioning screw. It is automatically brought to the correct position.

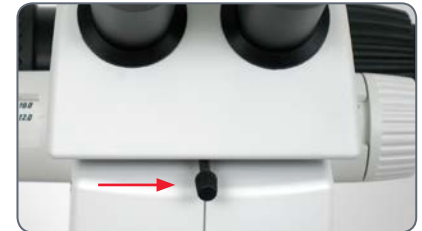

# Eyepieces

## Tools used

- No tools required.

## Magnification range

You can extend the overall magnification range using available 10×, 16×, 25× and 40× wide-field eyepieces for persons wearing glasses.

## Preparation

1. If you want to use an optional graticule, insert it now ([page 71](#)).
2. Remove the plastic tube guard.



## Inserting the eyepieces

3. Push the eyepieces into the tubes as far as they will go and check to ensure that they fit tightly and accurately.



4. Securely tighten the clamping screws.



# Objective

## Tools used

- No tools required.

## Preparation

1. Remove the protective cap on the optics carrier by turning it.



## Attaching the objective



Hold the objective firmly during assembly and disassembly so that it does not fall onto the stage plate. This applies particularly to the 2× planapochromatic objective, which is very heavy. Remove all specimens from the stage plate first.

2. Screw the objective clockwise into the optics carrier.



## Alternative fastening options

- If using the objective nosepiece, read the instructions on [page 25](#).
- If using the AX carrier, read the instructions on [page 27](#).



# Objective Nosepiece – Assembly

## Preparations



Hold the objectives firmly during assembly and disassembly so that they do not fall onto the stage plate.

- Move the drive housing all the way upwards and remove the optics carrier, if the carrier has already been installed.

## Assembly

1. Remove the transport anchor from the objective nosepiece.



2. Rotate the moving part by 90° and attach the objective nosepiece to the drive housing from the front (!). Screw the objective nosepiece firmly into place.



3. Unscrew the three Phillips screws on the objective mount of the optics carrier and remove the intermediate ring.



4. Screw the optics carrier onto the objective nosepiece.
5. Screw both objectives onto the objective nosepiece. It makes no difference which position an objective occupies.
6. Unscrew the locking screws on both sides of the objective nosepiece.



You can now adjust the parfocality (see instructions on the next page).

# Objective Nosepiece – Adjusting Parfocality

The following procedure only has to be carried out once. Afterwards, both objectives are parfocal, meaning that the specimen remains in focus when the objective nosepiece is rotated.

This procedure must be repeated if you replace either of the two objectives with another.

The following example assumes the combination of the 1× and 2× planapochromats. If you are using another objective combination, replace the 2× objective in the description with the objective with the stronger magnification.

## Preparation

- Open the iris diaphragm.
- Set the dioptic correction of the eyepieces to "0".

## Adjustment

1. Rotate the 2× objective into the beam path and set it to the lowest magnification.
2. Focus on the specimen.
3. Rotate the 1× objective into the beam path.
4. Turn the objective on the thread in both directions until the specimen appears sharp.
5. Toggle to the 2× objective.
6. Select the strongest magnification and refocus until the specimen appears absolutely sharp.

7. Toggle to the 1× objective.
8. Turn the objective on the thread in both directions until the specimen appears absolutely sharp.

By means of zooming, check that the behavior of the objective is parfocal. Repeat the check with the other objective. If it is not parfocal, repeat the procedure.

9. Tighten the locking screws.



# AX Carrier – Preparation

## Tools

- Hex socket screwdriver, 2.5 mm

## Preparing the AX carrier

Before the AX carrier is installed, it may first have to be prepared for the optics carrier to be used (Leica M125 C, M165 C, and M205 C).

1. Check the switch position.



- If the switch position corresponds to the optics carrier used, skip the following steps. Otherwise, proceed as follows:

2. Unscrew the two screws that hold the switch in position.



3. Pull out the switch, rotate it into the desired position and reinsert it.



4. Important: push the switch all the way into the mount while reinserting the screws. Only this ensures that the switch is positioned correctly.



# AX Carrier – Assembly

## Tools

- Hex socket screwdriver, 4 mm
- Philips screwdriver

Once the AX carrier has prepared for the corresponding optics carrier, it can be installed.

1. Move the slide of the AX carrier into mid position.



*Wrong*



*Right*

2. Install the AX carrier on the focusing column.



3. Screw the objective to the AX carrier.



4. Unscrew the three holding screws and remove the adapter ring on the optics carrier.



5. Install the optics carrier on the AX carrier.

# Transmitted-light Base Leica TL ST

## Unpacking the base

The base is delivered with the adapter plate installed. Make sure the devices are unpacked on a flat, sufficiently dimensioned, and non-slip surface.

## Focusing drive and column

1. Unscrew the extension plate from the base using the Allen key provided.

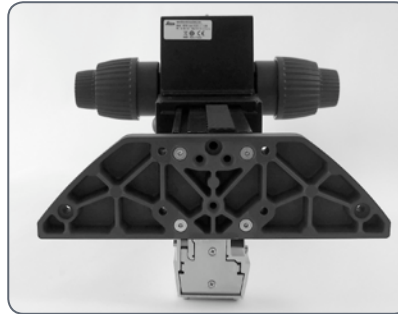

2. Attach your focusing drive column to the bottom using the 4 Allen screws.
3. Reattach the adapter plate to its original position using the 6 Allen screws.

# Transmitted-light Base Leica TL BFDf: Before First Use

## Removing the transport anchors



Before you can use the transmitted-light base for the first time, it is absolutely necessary to remove the two transport anchors as follows.



# Transmitted-light Base Leica TL BFDf

## Standard delivery

The base is delivered with the adapter plate installed. The selected stage (IsoPro cross-stage or standard stage 10 450 562), and the focusing drive will have to be mounted later.

## Stage assembly

The TL BFDf transmitted-light base can be equipped with three different stages.

- Leica IsoPro manual cross-stage
- Leica IsoPro automatic cross-stage
- Standard stage 10 450 562

The selected stage is mounted on the base before commissioning. You can switch between the stages at any time with just a few hand movements.

The following paragraph assumes use of the base without the stage mounted. Disassembly is performed in reverse order of the following steps.

## Standard stage

1. Take the glass plate from the rectangular gap in the standard stage.
2. Position the stage on the transmitted-light base in such way that the four holes align over those in the base.
3. Attach the stage to the base using the four Allen screws provided.
4. Insert the glass plate back into the standard stage.

## Leica TL RC / Leica TL RCI

The base is delivered with the adapter plate installed. The selected stage (IsoPro cross-stage or standard stage 10 450 562), and the focusing drive will have to be mounted later.

Ensure that the instruments are unpacked on a level, adequately sized, and nonskid underlay.

### Stage assembly

The transmitted-light base TL RC/ RCI can be equipped with three different stages. The selected stage is mounted on the base before commissioning. You can switch between the stages at any time with just a few hand movements.

The following paragraph assumes use of the base without the stage mounted. Disassembly is performed in reverse order of the following steps.

### Standard stage

1. Take the glass plate from the rectangular gap in the standard stage.
2. Position the stage on the transmitted-light base in such way that the four holes align over those in the base.
3. Attach the stage to the base using the four Allen screws provided.
4. Insert the glass plate back into the standard stage.



# Leica IsoPro Manual Cross-stage: Assembly

## IsoPro Cross-stage

Before the IsoPro cross-stage is mounted to the base, the axis containing the control buttons is attached either on the left or the right side of the cross-stage.

If the controls are to be mounted on the left-hand side, the gear rod on the bottom side of the cross-stage must be unscrewed and reattached in reverse.

1. Take the glass plate from the cross-stage.
2. Turn the cross-stage around and place it onto a non-slip surface.
3. Change the gear rod from the left to the right-hand side.
4. Skip the next two steps to mount the controls.

Before the IsoPro cross-stage is mounted to the base, the axis containing the control buttons is attached either on the left or the right side of the cross-stage.

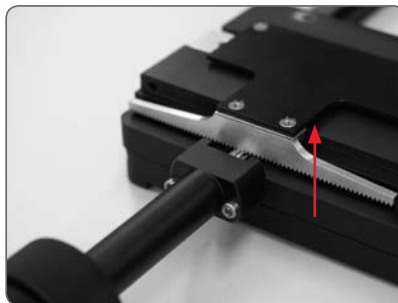

## Left or right operation

If the controls are to be mounted on the left-hand side, the gear rod on the bottom side of the cross-stage must be unscrewed and reattached in reverse.

## Leica IsoPro Manual Cross-stage: Assembly (Continued)

1. Take the glass plate from the cross-stage and turn it around.
2. Change the gear rod from the left to the right-hand side.

### Control assembly

1. Take the glass plate from the cross-stage and turn it around.
2. Attach the axis with the control buttons to the desired side. The fastener snaps into the cross-stage magnetically.
4. Attach the axis with the two Allen screws provided.
5. Attach the cover rail to the cross-stage.

### Cross-stage assembly

1. Place the cross-stage on the base.
2. Pull the upper part of the cross-stage carefully toward the user, fastening the lower part onto the transmitted-light base.

## Leica IsoPro Manual Cross-stage: Assembly (Continued)

3. Screw the cross-stage evenly onto the three threaded holes.
4. Push the cross-stage all the way back towards the column.
5. Reinsert the glass plate back into the standard stage.

### **Focusing drive and column**

1. Unscrew the extension plate from the base using the Allen key provided.
2. Attach your focusing drive column to the bottom using the three Allen screws.
3. Reattach the adapter plate to its original position using the three Allen screws.

# Leica IsoPro Motorized Cross-stage: Assembly

## Basics

The transmitted light bases of the TL series (TL BFDf, TL RC, TL RCI) are supplied with an installed extension plate. The selected stage (IsoPro cross-stage or standard stage 10 450 562), and the focusing drive will have to be mounted later.

The motorized cross-stage is a sensitive precision instrument. During installation, avoid subjecting the stage to impact or severe vibrations.

1. Unpack the cross-stage from the transport packaging and position it on the transmitted-light base.

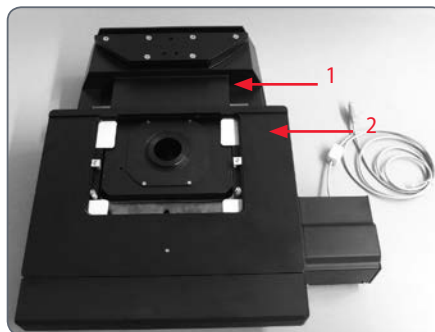

1. *Microscope base*
2. *Motorized cross-stage*

2. Secure the motorized cross-stage to the base using 3 M4 screws.

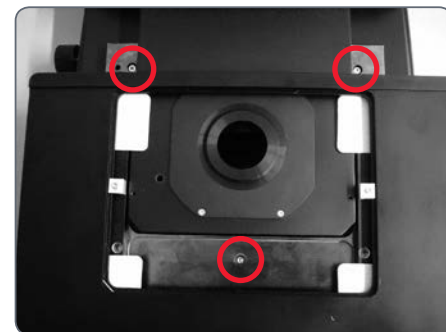

3× M4 screws

## Leica IsoPro Motorized Cross-stage: Assembly (Continued)

3. Remove the two M3 screws and the holder from the cross-stage.

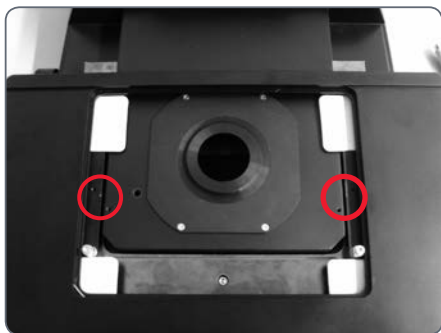

4. Remove the two M4 screws and the sleeve from the cross-stage.

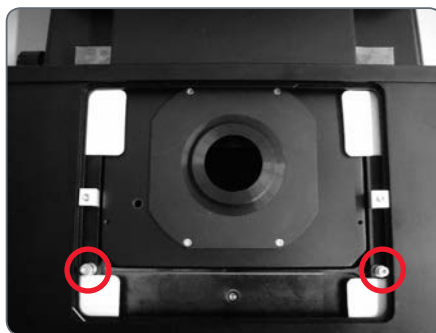

5. Remove the four shock-absorbing cartons from the cross-stage.

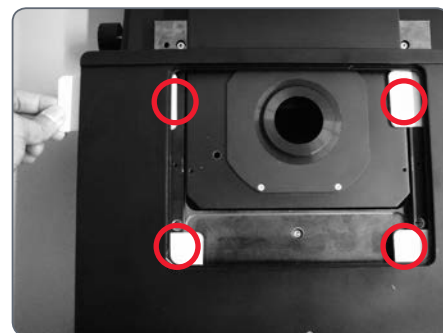

 After removal, keep all the transport anchors in the plastic bag for future transport.

# Leica IsoPro Motorized Cross-stage: Assembly (Continued)

## The bases

The TL BFDf, TL RC and RCI transmitted light bases can be equipped with three different stages: standard stage, manual and IsoPro automated cross-stage. The selected stage is mounted on the base before commissioning. You can switch between the stages at any time with just a few hand movements.

The following paragraph assumes use of the base without the stage mounted. Disassembly is performed in reverse order of the following steps.

## Cross-stage and base



Never move the sledge of the motorized cross-stage manually in the X direction, as otherwise the mechanical system will be damaged!

1. Place the cross-stage on the base.
2. Pull the upper part of the cross-stage carefully toward the user, fastening the lower part onto the transmitted-light base.
3. Screw the cross-stage evenly onto the three threaded holes.
4. Push the cross-stage all the way back towards the column.
5. Reinsert the glass plate back into the standard stage.

# Leica IsoPro Motorized Cross-stage: Assembly (Continued)

## Cross-stage for X-Y stage control module

1. Plug the CTL2 plug of the cross-stage motor into one of the three available CTL2 interfaces.
  2. Plug the CTL2 plug of the Leica PSC controller into another CTL2 interface.
    - The third CTL2 interface is available for connecting other instruments, such as the Leica foot switch (10 447 398) or TL RCI transmitted light base (10 446 352).
    - The 15-pin Sub-D interface is intended for use with the Leica SmartMove controller (11 501 197).
  3. Plug a power cable into the socket provided and into a grounded power socket.
- As soon as all instruments have been plugged into the control box and it has been plugged into the power supply, the cross-stage initializes and automatically drives to the mid position.
4. Connect the PC and X-Y stage DCI module (with a suitable USB cable).

# Cables: Terminals

The new Leica M series features extensive encoding with which various microscope data and settings can be read out, transferred to the PC and reproduced later.

- The interface to the optics carrier is on the column.



## The terminals

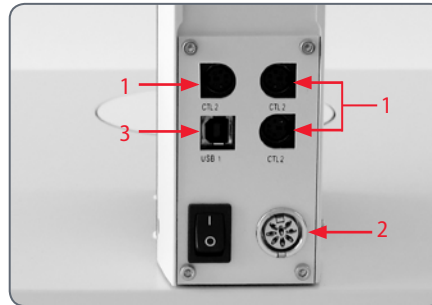

The connection to the PC and to other instruments is made using the terminals on the rear side of the column:

1. 3×CTL2 terminals for auxiliary equipment such as the ring illuminator, the base and other accessories from the Leica product range.
2. Terminal for the power supply provided.
3. USB terminal for the connection to the PC.



## Cables: Cable Duct

The integrated cable duct in the column enables a neat cable layout around the microscope. For example, the USB or FireWire cables of the camera can be stowed in the cable duct.

### Feeding the cables

1. Unscrew the three screws on the cable duct.

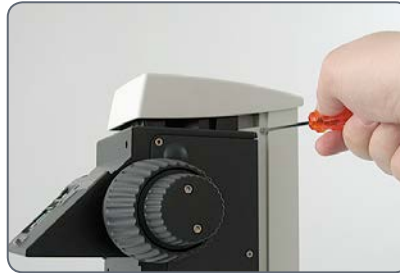

2. Remove the cover of the cable duct.

3. Place the cables in the cable duct and screw the cover on tightly.

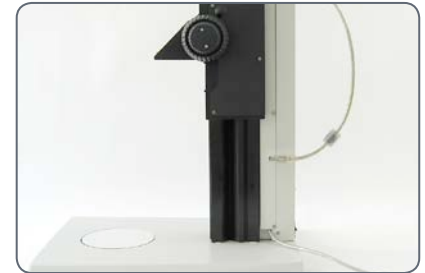

Tip: Estimate the length of the cable ends you will need before screwing on the cover. For thick cables, it is difficult to change the length retroactively.

# Cables: Diagram

..... Alternative installation

Please use the Leica Application Suite to configure the functions of the system.

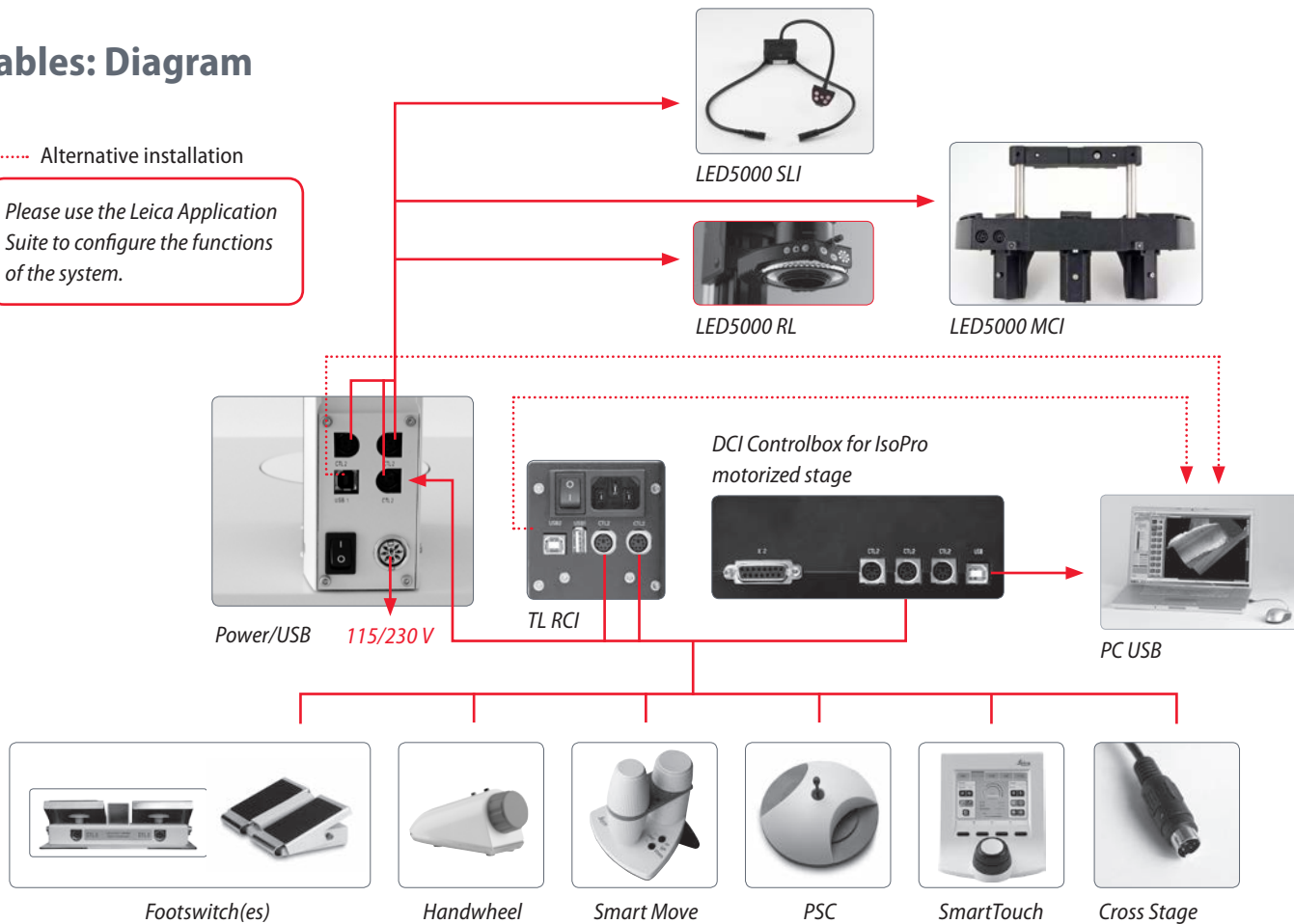

# Leica LED5000 MCI

The Leica LED5000 MCI (for "Multi Contrast Illumination") is installed using two screws. For optimum accessibility, the optics carrier should be removed during installation (see [page 21](#).)



## Constraints

The Leica LED5000 MCI cannot be used together with the objective nosepiece.

## Assembly



1. Hold the LED5000 MCI with one hand and tightly screw the retraining stirrups on both top holes on the drive housing.

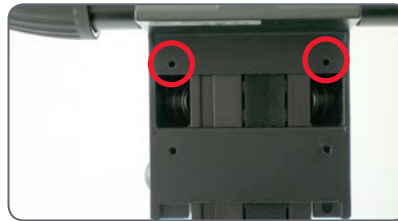

2. Connect the CAN-bus cable to either of the two sockets. (The flat part of the plug must be facing downwards.)



3. Plug the other end of the cable into one of the three "CTL2" sockets on the column.



## Leica LED5000 MCI: Alternative Assembly

Under certain circumstances, the light source must not be moved along with the optics carrier. A typical example is multifocus images in which the Z-stack changes while the angle of incidence of the light must remain the same. For such purposes, the Leica LED5000 MCI is directly fastened to the column.

### Installation on the column

1. Pull the retaining stirrup out of the Leica LED5000 MCI.



2. Screw the retaining stirrup into the column at the notch using the single screw. If you tighten the screw, the retaining stirrup is automatically moved into the correct position.

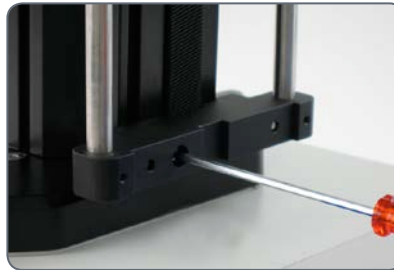

3. Push the Leica LED5000 MCI onto the retaining stirrup.

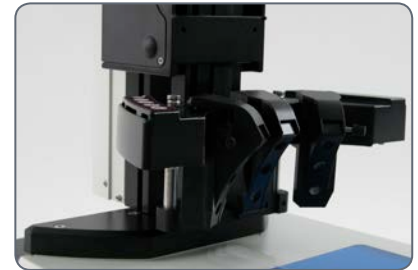

# Leica LED5000 RL: Assembly

## Required tools

- None

 The Leica LED5000 RL is installed on the objective using a single screw. It has been optimized for a working distance between 50 mm and 80 mm.

## Constraints

The Leica LED5000 RL can be used only in conjunction with the planapochromat 1× and planapochromat 0.63× objectives. With all other objectives, the working distance is too low for adequate illumination.

The ring illuminator cannot be used together with the objective nosepiece.

## Assembly

1. Connect the Leica CAN bus cable provided to the ring illuminator.



2. Place the Leica LED5000 RL against the objective from below, push it up as far as it will go and screw it into place.





3. Plug the other end of the cable into an available CTL2 socket on the column.



*Continued on next page.*

## Leica LED5000 RL: Assembly (Continued)

 If you work with the manual focusing column without integrated electronics, the Leica LED5000 RL must be supplied with power via an external power supply unit (not included in the delivery package). Moreover, the illuminator cannot be controlled via Leica Application Suite in this case.

 For optimum accessibility of the specimen, the ring illuminator should be installed with the cable facing backwards. However, it is also possible to turn the ring illuminator sideways, for example if simultaneously using the Leica LED5000 MCI system illuminator. In this case, the ring illuminator cannot be connected directly to the Leica LED5000 MCI.

# Leica LED5000 RL: Installing Optional Accessories

## Installing optional accessories

- You can screw the optional polarization set into place firmly using the metal plate provided.



- The optional polarization set (polarizer and analyzer) is attached and screwed in below the ring illuminator.



- The optional diffuser is attached and screwed in below the ring illuminator.



# Leica LED5000 RL: Use



The light of the Leica LED5000 RL can be very bright. Therefore, always switch on the illuminator *before* you look through the eyepieces! Avoid looking directly into the LEDs.



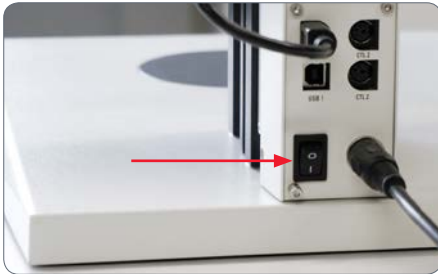

## Switching on the focus column

1. Switch on the focus column using the power switch on the rear in order to supply the Leica LED5000 RL with current.







## Using the front keypad









- Use the  key to switch the illuminator on or off.
- Use the  or  keys to adjust the brightness in 10 increments.
- Tap the  or  key briefly to adjust the intensity in small increments. Hold one of the keys to change the intensity more quickly.

## Using the side keypad

- Use the  and  keys to toggle between the illuminator segments.
- Use the  key to toggle between the following illuminator segments: full ring, half ring (left–right), half ring (front–rear), quarter ring, opposite quarter rings, eighth ring.
- Use the  and  keys to rotate the active segments clockwise or counterclockwise.



## Leica LED5000 RL: Use (Continued)

- If you press  or  for approx. 2 seconds, the segments rotate automatically until you press one of these keys again. If you change the segment using the  key, the automatic changeover is kept. Pressing  or  briefly stops the changeover.
- Press and hold the  key for approx. 2 seconds to switch on the full ring of the ring illuminator.



The active illuminator segments are indicated on the front control panel by 8 LEDs arranged around the on/off key.

# Leica LED5000 NVI: Assembly on High-Performance Stereo Microscopes (Leica M125 C / Leica M165 C / Leica M205 C)

## Assembly of the Leica LED5000 NVI (10 450 659)

1. The Leica LED5000 NVI in factory configuration is already assembled with the extension plate (for assembly on manual and motorized focusing columns) at the factory.



2. Place the Leica LED5000 NVI on the focusing column so that the screw fits into the thread provided and the lug fits into the groove.



3. Press the Leica LED5000 NVI backwards to the focusing column and screw it in place using an Allen key M4.



# Leica LED5000 NVI: Assembly on High-Performance Stereo Microscopes (Leica M125 C / Leica M165 C / Leica M205 C) (Continued)

4. Unscrew the three Phillips screws on the objective mount of the optics carrier and remove the spacer ring.



5. Set the optics carrier on the adapter of the Leica LED5000 NVI and tighten it with an Allen key M4.

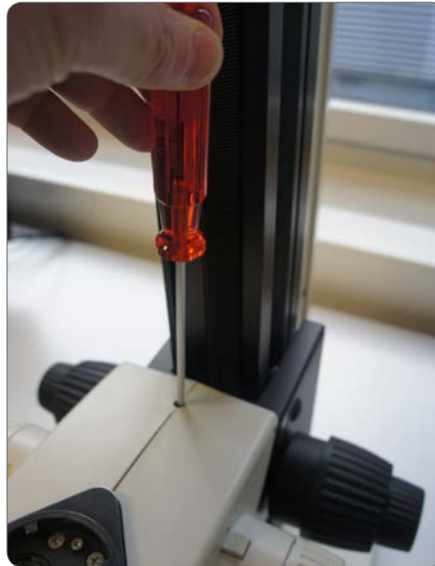

6. Install the remaining microscope components (tube, ergonomic accessories, camera etc.) according to the corresponding user manuals.

7. If the focusing column is equipped with integrated electronics, connect the Leica LED5000 NVI to the focusing column via the CTL2 connection. Alternative installation for manual columns: Connect the external power supply unit (10 450 266) to the Leica LED5000 NVI.



## Leica LED5000 NVI: Assembly on High-Performance Stereo Microscopes (Leica M125 C / Leica M165 C / Leica M205 C) (Continued)

8. Screw the objective to the Leica LED5000 NVI from below.



Lists of recommended objectives that can be used with the Leica LED5000 NVI without additional adapters:

- 10 411 597 Achromatic objective f=100 mm
- 10 441 787 Achromatic objective f=150 mm
- 10 431 692 Achromatic objective f=175 mm
- 10 382 162 Achromatic objective f=200 mm
- 10 382 172 Achromatic objective f=400 mm
- 10 450 027 Planapochromatic objective 0.63×
- 10 450 028 Planapochromatic objective 1.0×
- 10 450 029 Planapochromatic objective 1.6×
- 10 450 030 Planapochromatic objective 2.0×

Additional objectives can be used by means of adapters. However, loss of optical quality does need to be expected (e.g. vignetting, color seams, reflections etc.).

# Leica LED5000 NVI: Installing Optional Accessories

## Polarization set

The Leica LED5000 NVI can be equipped with an optional polarization set. Using the polarization set, reflections can be reduced on metallic surfaces, for example.

1. The polarizer is inserted into the filter insert on the bottom of the Leica LED5000 NVI.



2. The analyzer is installed between the tube and optics carrier. To do so, remove the tube from the optics carrier. Place the analyzer on the optics carrier and then install the tube. Fasten the components by tightening the positioning screws.



3. To generate the desired polarization effect, rotate the rotary disk of the analyzer until the desired image quality is reached.

## Leica LED5000 NVI: Installing Optional Accessories (Continued)

### Filter inserts

The Leica LED5000 NVI is supplied with a filter holder as a standard feature. Commercially available filters of size 1/2" can be used. Make sure that the filters being used are sufficiently temperature-resistant, so they are not damaged by the high-energy illumination. Additional empty filter inserts (10 725 035) can be purchased as spare parts.

1. To disassemble the filter holder, push the filter holder approx. 1 cm to the side and remove the holder downwards out of the Leica LED5000 NVI. The filter holder is assembled in the reverse order of steps.



# Quick Start Guide



# The Fastest Route to Success

Your Leica stereo microscope has been delivered in completely assembled condition by your Leica partner, and naturally you want to get right to work. Therefore, your next step should be to study the Quick Start Guide, which outlines the most important steps at a glance.

This manual will then familiarize you with the finer details of your microscope. The following pages contain important, practical information that makes using it every day easier.

Take time to read it – it's worth it!

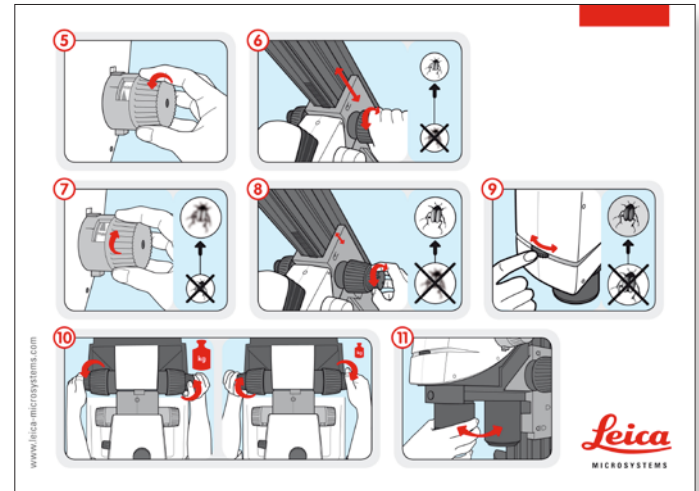

*The M series quick start guide (included with instrument)*





# The Correct Interpupillary Distance

The interpupillary distance is correctly set if you see a single circular image field when looking at a specimen.

If you are still a novice microscope user, you may need a short time to become accustomed to this. Not to worry – after a little while, it will become automatic.

## Reference value

The distance between eye and eyepiece measures approx. 22 mm for 10/23B wide-field eyepieces for persons wearing glasses.

## Adjusting the interpupillary distance

1. Look into the eyepieces.
2. Hold the eyepieces with both hands. Push the eyepieces together or separate them until you see a circular image.

3. Slowly approach the eyepieces with your eyes until you can see the complete image field without corner cutting.

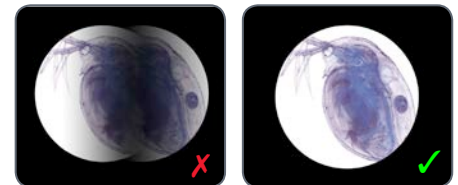

# Using the Eyepieces

The eyepieces form the connection between the tube and the eye of the observer. Simply push them into the tube and they are ready to use.

Each eyepiece offers a certain magnification factor that has a determinative effect on the total magnification. Furthermore, all Leica eyepieces can be equipped with practical graticules that enable measuring and quantifying of specimens.

## Dioptric correction

A built-in dioptric correction is available for eyeglass wearers. For more information, refer to [page 69](#).

### If you do not wear glasses:

1. Hold the eyepiece firmly and rotate the eyecups forwards counterclockwise.
2. If an eyepiece is equipped with the inte-



grated dioptric correction, turn the value to the "0" mark.

### If you wear glasses:

1. Hold the eyepiece firmly and rotate the eyecups counterclockwise towards the rear, as otherwise the viewing distance is too great.
2. If an eyepiece is equipped with the inte-



2. If an eyepiece is equipped with the integrated dioptric correction, turn the value to the "0" mark.

By the way, one benefit of viewing with eyeglasses is a drastically lower risk of bacterial transmission (see [page 68](#)). The soft material of the eyecup also ensures that your glasses will not be scratched, even if they contact the eyepiece.

# Focusing

Focusing raises or lowers the stereo microscope using the focusing drive. The specimen detail is brought into sharp focus as soon as it is in the focal point of the objective.

- The focusing drive can be operated either left- or right-handed.



## Focusing

- The inner, coarse adjustment is used for covering great distances.
- The outer, fine adjustment is used for fine focusing.



## Coarse/fine adjustment

The sharpness is adjusted using the coarse/fine adjustment.



The coarse/fine adjustment carries a load of up to 15 kg.

- The resolution of the coarse/fine adjustment is 1  $\mu\text{m}$ .

# Adjusting the Resistance of the Focus Drive

## Adjusting the resistance

Is the focus movement too loose or too tight? Does the outfit tend to slide downwards? The resistance can be adjusted individually depending on the equipment weight and personal preferences as follows:

1. Grip the outer drive knobs with both hands and turn them towards each other until the desired resistance is reached during focusing.



# Changing the Magnification (Zoom)

All M series microscopes have an integrated zoom. The name indicates the zoom range covered:

- Leica M125 C = 12.5:1
- Leica M165 C = 16.5:1
- Leica M205 C = 20.5:1

The rotary knob for the zoom can be used either left or right-handed.

## Zooming

1. Look into the eyepieces.
2. Focus on the specimen.
3. Rotate the magnification changer until the desired magnification is configured.



# Ratchet Steps and Magnification Levels

The zoom button can optionally be operated either with or without ratchet steps. Continuous zoom is possible when the ratchet steps are disabled, which many users find convenient. On the other hand, when the ratchet steps are enabled, photographs, measurement results etc. can be reproduced more accurately.

## Enabling and disabling ratchet steps

1. Push the top button downwards to disable the ratchet steps.
2. Push the bottom button upwards to enable the ratchet steps.



## Magnifications and fields of view

The formula on [page 120](#) provide additional information about the magnifications and field of view diameters, with consideration given to the position of the magnification changer and the eyepiece and objective combination used.

# Parfocality: More Comfort and Convenience for Your Work

All Leica stereo microscopes are parfocally matched, meaning that you can view a focused specimen from the lowest to the highest magnification without having to refocus. There is no need to readjust the focus to view of specimen location that is located higher or lower.

## Requirements for parfocal work

- If you are using an eyepiece with dioptic correction, the procedure differs from this description. For more information, refer to [page 70](#).
- For the procedure for adjusting the parfocality for the objective revolver, refer to [page 26](#).

## Parfocality

1. Enlarge the view to the maximum level.
2. Focus on the specimen.

You are done! Even if you select a smaller working distance, the specimen remains pin-sharp.

The parfocality is maintained until you focus on another level of the specimen.



# Iris Diaphragm

The iris diaphragm in the optics carrier of your M series microscope has the same purpose as those in a camera shutter: it regulates the available light, which changes the depth of field. The "depth of field" is the area of a specimen that is brought into sharp focus.

## Closing the iris diaphragm

- Close the iris diaphragm by turning the knob to the left. The subject appears darker and the depth of field increases.



## Opening the iris diaphragm

- Open the iris diaphragm by turning the knob to the right. The subject now appears brighter, but the depth of field decreases.



# Eyepieces

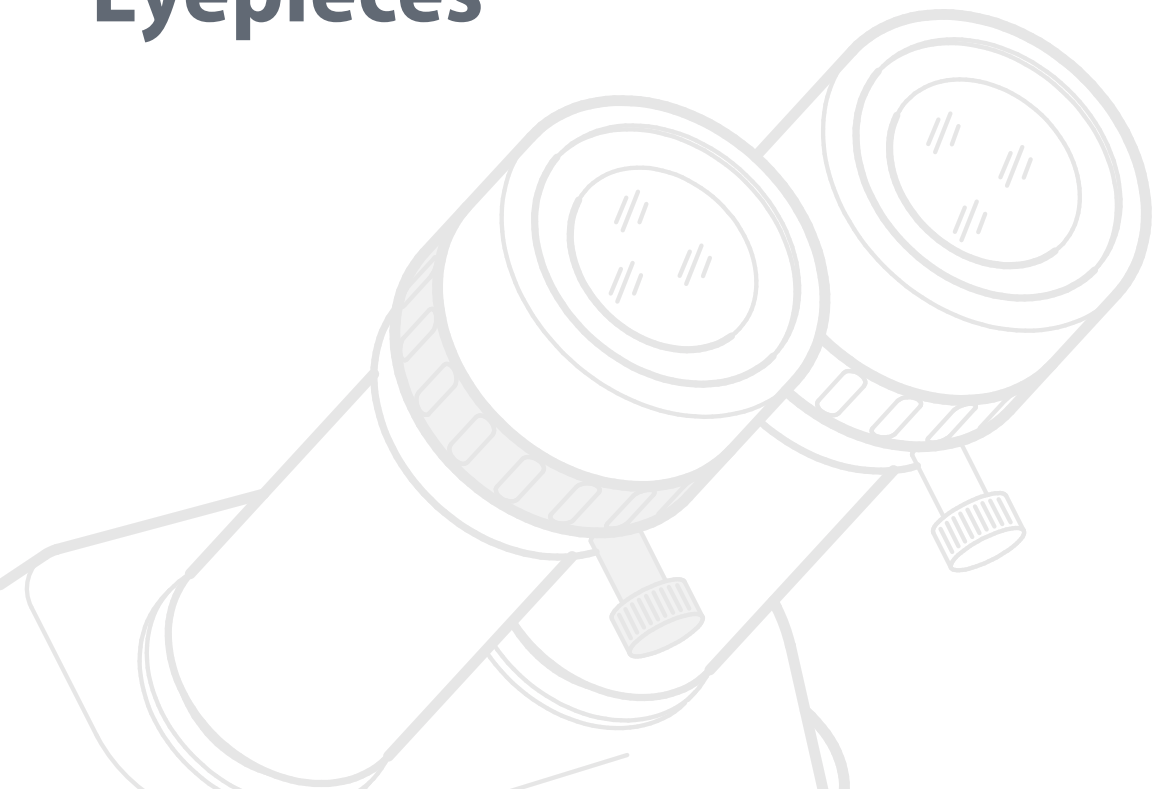

# Magnification Factors of the Eyepieces

An eyepiece not only makes it possible to look passively into the microscope, but also has a critical effect on the maximum magnification. The magnification factor is between 10× and 40×.

---

**The following eyepieces are available for the M series:**

Magnification	Dioptric correction	Order number
10×	± 5 diopter settings	10 450 630
16×	± 5 diopter settings	10 450 631
25×	± 5 diopter settings	10 450 632
40×	± 5 diopter settings	10 450 633

# Health Notes

## Potential sources of infection



Direct contact with eyepieces is a potential transmission method for bacterial and viral infections of the eye. The risk can be kept to a minimum by using individual eyepieces or detachable eyecups. Eyecups can be ordered separately. Please contact your Leica partner.



*Separate eyecups are an effective way of preventing infections.*

# Dioptric Correction

All Leica eyepieces are also available with built-in dioptric correction, allowing the microscope to be used without glasses even by those with vision problems. The correction comprises  $\pm 5$  diopter settings.



## Using the dioptric correction

1. Set the dioptric correction of both eyepieces to the mid position ("0" diopter settings).
2. While wearing your glasses, look through the eyepieces and focus on the specimen.
3. Rotate both eyepieces to the maximum value of "+5".
4. Hold one eye closed and rotate the other eyepiece in "-" direction until the specimen appears sharp.
5. Then, open the other eye and correct the diopter settings until the image is uniformly sharp.

 Note that when using dioptric correction, the advantage of parfocality is lost – thus you have to manually refocus each time you change the zoom level. To also use parfocality with dioptric correction, refer to the instructions on [page 70](#).

# Dioptric Correction and Parfocality

Leica stereo microscopes are parfocally matched. The prerequisite for this is the correct setting of the diopters and the parfocality. The following adjustments only have to be carried out once by each user.

## Preparations

- Move the lever of the video/phototube to the "observation" position and open the diaphragm.
- If you are using the microscope carrier AX, set it to stereoscopic observation.

## Adjusting

1. Set the dioptric correction for both eyepieces to "0".
2. Select the lowest magnification and focus on a flat specimen.
3. Select the highest magnification and readjust the sharpness.
4. Select the lowest magnification again, but do not look into the eyepieces.
6. Rotate the eyepieces counterclockwise in the "+" direction as far as they will go (+5 diopter settings).

7. Look into the eyepieces.
8. Slowly rotate each eyepiece individually in the "-" direction until each eye sees the object sharply imaged.
9. Select the highest magnification and refocus if necessary.

Now, if you adjust the magnification from the lowest to the highest level, the specimen is always brought into sharp focus. If not, repeat the process.

# Graticules

## Use

Graticules make length measurements and counting easier, particularly for workstations that are not equipped with a digital camera and LAS software.

The graticules for length measurements and numbering are fitted in mounts and are inserted into the eyepieces.

1. Screw the insert off of the eyepiece.



2. Clamp the graticule on the insert, applying moderate pressure. Ensure that the graticule fits tightly.



3. Screw the insert and graticule firmly into place and replace the eyepiece in the tube.



4. You can now align the graticule by rotating the eyepiece in the tube and then tightening it using the clamping screw.



## Use with the AX carrier

 If possible, measure with the microscope carrier AX in vertical position. The measurements are more accurate without the convergence angle in the stereoscopic image.

# Photography & Video

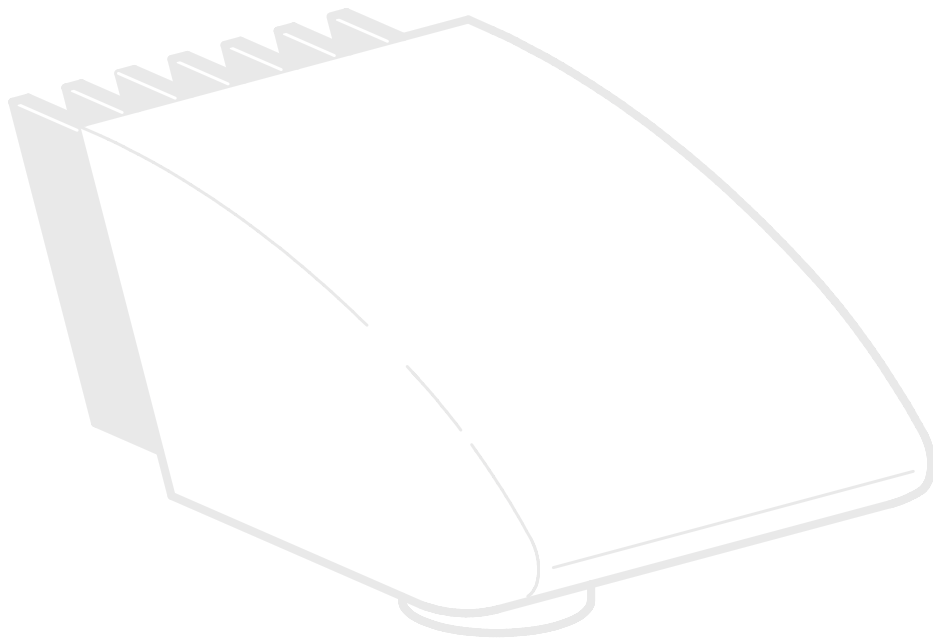



# Photography & Video

For most microscope users, digital documentation has become an invaluable part of their work. Research results can be presented in an attractive manner; measurements on the digital image provide clarity and, in conjunction with the motorized IsoPro cross-stage, even images of large specimens can be captured step by step and automatically joined to create a new complete image.

## Adapter

If camera control using the Leica Application Suite is not required, conventional mirror reflex and rangefinder cameras from third-party manufacturers can be used. For this purpose, Leica Microsystems offers a variety of adapters that can be used together with the 50 % and 100 % trinocular tubes.

## Leica cameras

However, if you require absolute control over the camera and need the capability for measurement, evaluation and more in addition to photography, the digital Leica cameras are exactly right for you. Together with the Leica Application Suite, they provide virtually limitless freedom of use. For additional information about Leica cameras, refer to the camera's documentation.



## Leica Application Suite

The "Leica Application Suite", or "LAS" for short, is, as it were, the digital extension of the Leica M series microscopes. In addition to capturing images, it lets you control the microscope, illuminator, stages, cameras and more. For additional information, refer to the LAS online help.

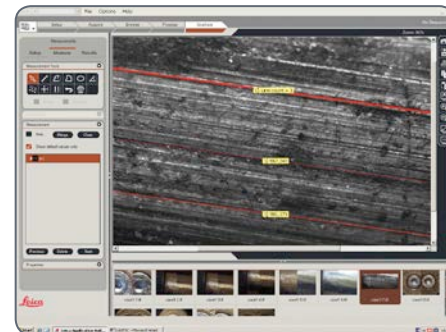

# Photo Tubes and C-mounts

## Application

All Leica DFC/DMC/MC cameras are equipped with a standardized C-mount interface. In turn, the C-mount adapter for the respective trinocular tube is connected to this interface. This adapter creates a solid mechanical connection between the microscope and camera and ensures optimum rendering of the microscopic image on the image sensor of the camera.

Usually, the ideal is for the digital camera to capture as much of the field of vision as possible, while excluding as much of the black edge of the field of vision as possible. To do so, the magnification factor of the C-mount adapter must match the image format of the sensor as closely as possible (see table).

If there is unwanted shading at the corners even with a compatible C-mount adapter installed, it can be corrected using the "Shading function" of the camera software.

Alternatively, you can also use a C-mount adapter with higher magnification. This primarily avoids the critical border area of the field of vision and concentrates on the center of the field of vision.

## Cameras from third-party suppliers

In addition to Leica cameras with the standardized C-mount interfaces, you can connect third-party cameras to the microscope using a T2 bayonet adapter.

To do so, instead of the C-mount adapter, simply use the corresponding SLR adapter with T2 connection. However, these third-party cameras are not integrated into the Leica Application Suite and have to be operated using the corresponding software from the camera manufacturer.

The Leica digital cameras are detailed in a separate user manual along with instructions for their assembly and use.

Name	MPixel	Sensor	Size	Pixel-Size	Cooling	Interface	C-Mount*
MC170 HD	5	CMOS-c	1/2.3"	2.35 µm	No	USB2 + HD	0.4x-0.5x
MC190 HD	10	CMOS-c	1/2.3"	1.67 µm	No	USB2 + HD	0.4x-0.5x
DMC2900	3	CMOS-c	1/2"	3.2 µm	No	USB3	0.5x
DFC295	3	CMOS-c	1/2"	3.2 µm	No	FWb	0.5x
DFC7000T	2.8	CCD-c	2/3"	4.54 µm	Yes	USB3	0.63x
DMC4500	5	CCD-c	2/3"	3.4 µm	No	USB3	0.63x
DFC450 C	5	CCD-c	2/3"	3.4 µm	Yes	FWb + Sync	0.5x
DFC495	8	CCD-c	2/3"	2.7 µm	Yes	FWb + Sync	0.63x
DFC550	12.5	CCD-c	2/3"	6.45 µm	Yes	FWb + Sync	0.63x
DFC3000 G	1.3	CCD-m	1/3"	3.75 µm	No	USB3 + Sync	0.35x-0.4x
DFC365 FX	1.4	CCD-m	2/3"	6.45 µm	Yes	FWb + Sync	0.7x

-c: color / -m: monochrome / \* recommended

Stereo 2016/V.1

# Trinocular Video/Phototube 50 %

## Use

With its third beam path, the trinocular video/phototube 50 % enables you to simultaneously view and photograph a specimen. The available light is divided as follows:

- 50 % is available for the two eyepieces.
- 50 % of the light is diverted to the video/photo beam path.



## Assembly

Fasten the "trinocular tube 50 %" to the optics carrier instead of the binocular observation tube (refer to [page 22](#)).

# Trinocular Video/Phototube 100 %

## Use

With its third beam path, the trinocular video/phototube 100 % enables you to either view or photograph a specimen. This means that 100 % of the light is available to one or the other beam path. The other beam path remains opaque or black.

## Assembly

Fasten the "trinocular tube 100 %" to the optics carrier instead of the binocular observation tube (refer to [page 22](#)).

## Switchover

- Turn the controller on the right side of the tube into the horizontal position in order to guide all available light into the eyepieces. You can now observe the specimen.
- Turn the controller on the right side of the tube into the vertical position in order to guide all available light into the camera. You can now photograph the specimen.



# Microscope Carrier



# The Microscope Carrier AX

Users who intend to do a great deal of photography, take measurements or work with polarization should select the microscope carrier AX for stereoscopic/axial observation. The parallax-free imaging by means of a perpendicular beam path leads to results without parallax error.

## Compatibility

The planachromatic and planapochromatic objectives fit into the thread in the microscope carrier AX for the Leica M125 C, Leica 165 C and the Leica M205 C.

## Stereoscopic viewing

A stereoscopic view is required for examining spatial objects. For this purpose, the microscope carrier AX must be brought to its home position.

1. Unscrew the clamping screw.



2. Push the microscope into the home position (mid position) to obtain a spatial view and tighten the clamping screw.

## The Microscope Carrier AX (Continued)

### Parallax-free images

The parallax-free imaging produces more precise results in photography, measuring and polarization.

1. Unscrew the clamping screw.
2. Push the microscope towards the left as far as it will go and tighten the clamping screw.



The objective is now located directly beneath either the left or the right beam path.

### Coaxial light and the Leica M205 C

When using coaxial incident light together with the Leica M205 C, unscrew the clamping screw and press the optics carrier towards the right (caution: the movement is only 2 mm). This provides uniform light intensity in both beam paths.

# The Objective Nosepiece

## Use

The objective nosepiece enables you to switch between two objectives using just one hand movement, for example between a 1× and a 2× planapochromat.



## Parfocal work

With the new M series objectives, the parfocality is maintained even when objectives are changed, meaning that the specimen remains in sharp focus during the change.



Older Leica objectives can continue to be used, but without parfocality during the objective change.

## Technical constraints



The objective nosepiece cannot be used together with the LED5000 MCI system illumination, as the objective nosepiece can no longer be rotated.



# Objectives and Optical Accessories



# The Different Types of Objectives

To meet the various requirements regarding imaging properties, there is a choice of high-quality interchangeable planachromatic and planapochromatic objectives and also lower-priced interchangeable achromatic objectives.

- Achromatic objectives are particularly suited for specimens with high-contrast structures.
- Flat-field (planachromatic) objectives are particularly well suited for studying flat objects such as wafers and thin sections.
- With planapochromatic objectives, the finest structures are visible with high contrast. The sophisticated apochromatic correction allows these objectives to attain the highest color brilliance and fidelity.

## Achromatic objectives

The 0.32×, 0.5×, 0.63×, 0.8×, 1×, 1.5×, 2× achromatic objectives offer countless variants for selecting the object field diameter, magnification ranges and working distances (see [page 120](#)).

## Planachromatic objective 1×

For the highest requirements for overall image quality, we recommend equipping the microscope with the 1× plan (flat-field) objective, which returns sharp, contrast-rich object fields.

## Achromatic objectives with a long focal length:

For special applications achromatic objectives with long working distances and focal lengths of  $f=100$  mm to 400 mm are available.

# Bases

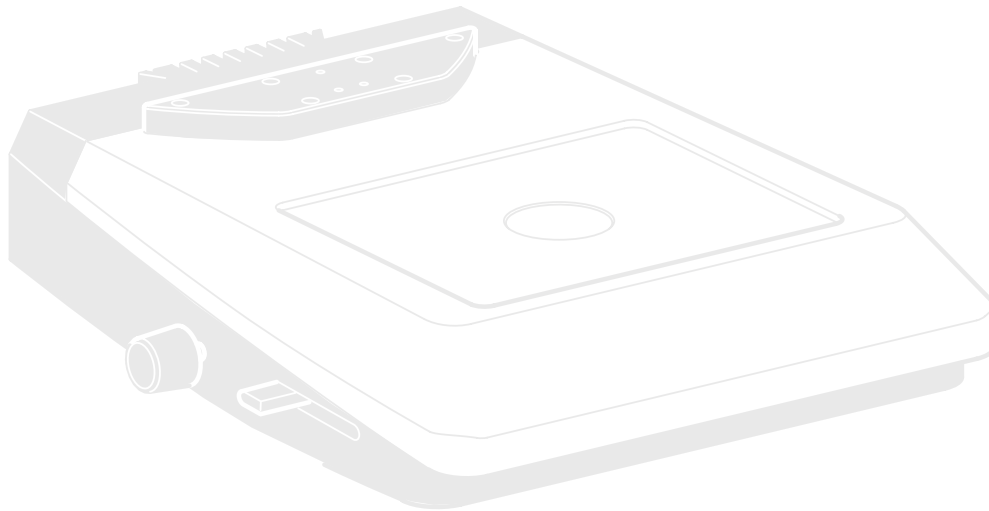

# Transmitted-light Base Leica TL ST: Controls

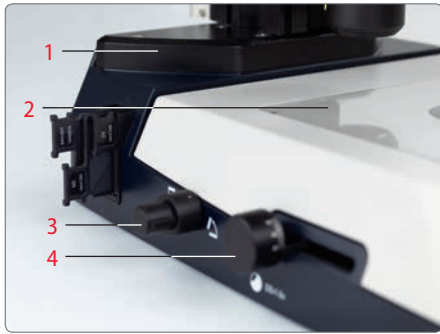

1. Adapter plate for easy assembly of focusing drives
2. Removable glass plate
3. Controller for light intensity
4. Adjustment for deflection mirror

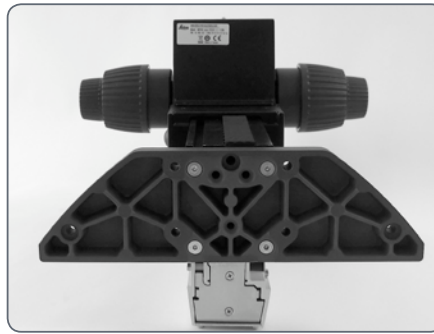

Extension plate of the transmitted-light base TL ST

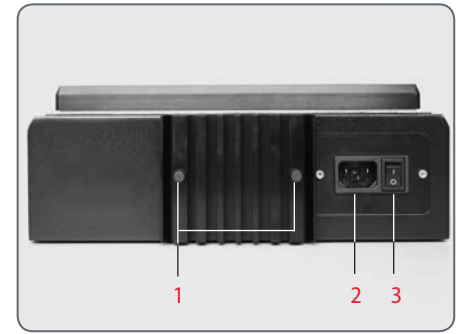

Rear side of the transmitted-light base TL ST

1. Screws for changing the halogen lamp
2. Power connection socket
3. Power switch

# Transmitted-light Base Leica TL ST: Operation

## Light intensity control

The left control adjusts the intensity of the 12V/20W halogen illumination.

1. Switch on the illumination of the base at the power switch.
3. Focus on the specimen.
3. Set the illumination to the desired intensity using the left control.



## Transmitted-light control

The transmitted-light base TL BFD has a slider that automatically moves the deflection mirror in the base when moved. The mirror is kept in the correct position at all times and permits smooth changeover between bright field and opaque transmitted light.



## Bright field

Bright field is suitable for examining translucent objects featuring contrasting structures. The object is directly illuminated from below and is seen in its natural colors against a bright background.

- Move the slider backwards until the desired effect is achieved.

## Inclined transmitted light

Transmitted light that traverses the object obliquely will produce effects advantageous for observing semitransparent, opaque objects.

- Slowly pull the slider towards yourself until the desired effect is achieved.

# Transmitted-light Base Leica TL ST: Lamp Replacement

## Changing the halogen lamp



Before you change the lamp, it is absolutely necessary to unplug the power plug from the base to prevent the risk of electric shock!



The halogen lamp becomes very hot during operation. Therefore, to avoid being burned, let the base cool off for approx. 10 minutes after switching it off!



Do not touch new halogen lamps with your bare fingers – this drastically reduces the service life of the lamp!

## Changing bulbs

1. Unscrew the two screws on the cooling unit and pull the cooling unit out, along with the lamp.



2. Carefully pull out the lamp and mount by pulling them upwards.
3. Disconnect the lamp from the mount.
4. Insert the new lamp into the mount and reinsert the lamp holder.

## Precautionary measures



When inserting the lamp, ensure that the cables are inside the two metal clamps. This prevents the cables from getting caught during insertion.

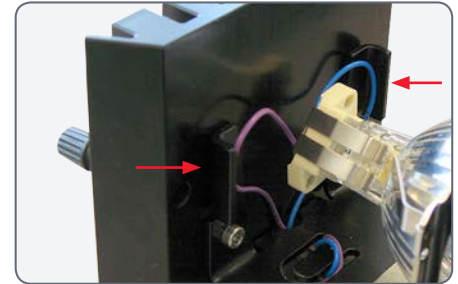

# Transmitted-light Base Leica TL BFDf: Controls

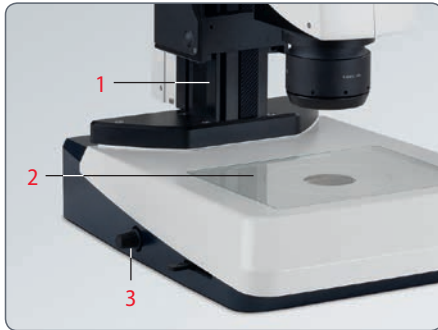

1. Adapter plate for easy assembly of focusing drives
2. Standard stage 10 450 562
3. Button to toggle between bright field and dark field

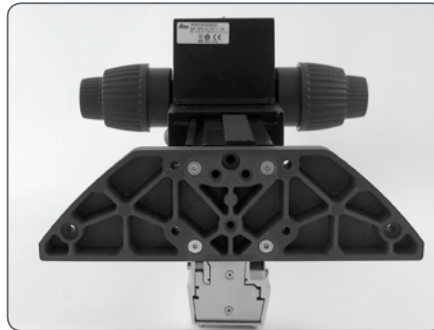

Extension plate of the transmitted-light base TL BFDf

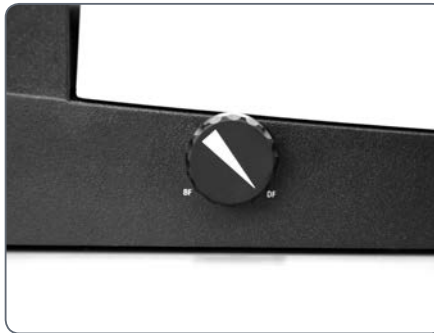

Button to toggle between bright field/dark field



Adapter at the focusing drive



Connector for cold light sources  
(light conductor active  $f = 10$  mm,  
end tube  $f = 13$  mm)

# Transmitted-light Base Leica TL BFDf: Operation

## Light intensity control



Please observe the user manual – in particular, all safety regulations – from the manufacturers of the light guide and cold light source.

- Switch on the cold light source according to the manufacturer's user manual and adjust the brightness.

## Transmitted-light control

The TL BFDf transmitted-light base has a potentiometer that switches the light from "bright field" to "dark field".

## Bright field

Bright field is suitable for examining translucent objects featuring contrasting structures. The object is directly illuminated from below and is seen in its natural colors against a bright background.

- Turn the control as far as it will go towards "BF" ("bright field").



*Fingertip with bright field illumination*

## Dark field

In dark-field illumination, a ring illuminator is used in such a way that the direct light does not reach the objective without a specimen. Only the structure of semitransparent, opaque objects disperses the light, making the object visible against a dark background.

- Turn the control as far as it will go towards "DF" ("dark field").

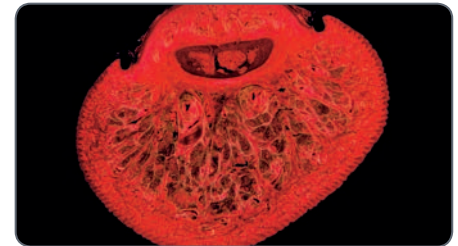

*Identical subject with dark field illumination*



## Leica TL RC / Leica TL RCI: Controls

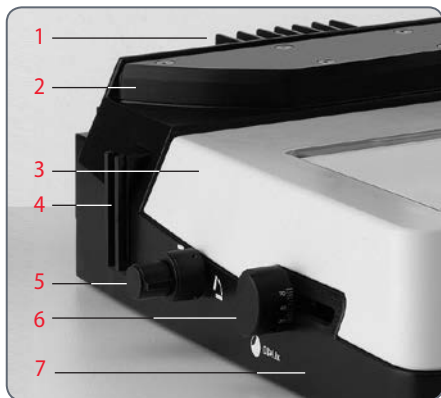

1. Heat sink of the integrated halogen illumination (only TL RCI)
2. Extension plate for focusing drives
3. Standard stage 10 450 562
4. Filter holder
5. Control of top and bottom flaps of the Rottermann Contrast
6. Button for mirror and horizontal movement of the mirror
7. Transmitted-light base

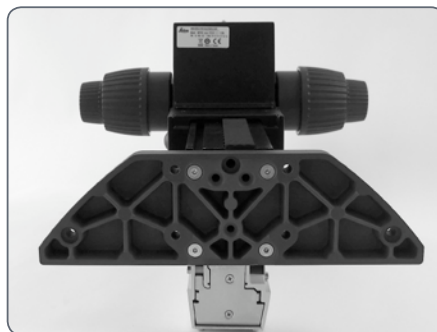

Vertical column – transmitted-light base adapter plate

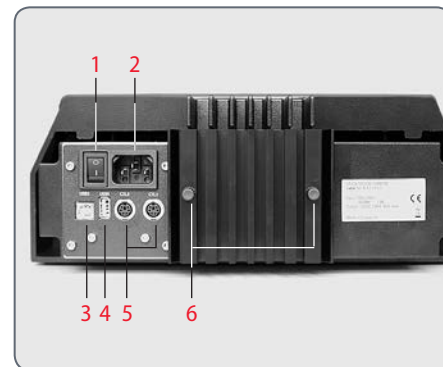

1. Power switch
2. Power connection socket
3. USB socket, type B
4. USB socket, type A
5. 2x CAN bus
6. Screws for changing the halogen lamp

# Leica TL RCI: The Deflection Mirror



## Inverted world?

Depending on the properties of the specimen (refractive index of the environment) and the perception of the viewer, it is possible that the switches described below for positive and inverted relief contrast are to be operated in reverse. This means that the lower switch, rather than of the upper switch, controls inverted relief contrast and vice-versa.

## Tilted mirror

The built-in mirror features one flat and one concave side and can be rotated and moved. The concave side has been specially designed for the optical requirements of objectives with a high numerical aperture. The black rotary knob on the left side of the transmitted-light base can be used to rotate the built-in path-folding mirror and move it forwards/back.

The concave cutout on the handle indicates the concave side of the mirror, allowing intuitive operation at any time without eye contact.

The angle of light incidence in the specimen plane changes depending on the tilt and position of the mirror. As a result, switching between transmitted light bright field, oblique illumination and dark field-like illumination is possible.

## Functions of the rotary knob

The rotary knob (1) fulfills the following tasks:

- Turning the deflection mirror from the flat to the concave side.
- Slight tilting to guide the light beam through the specimen plane at a steeper or flatter angle
- Moving the deflection mirror (forwards/back)

# Leica TL RCI: Color Intensity and Temperature



1. Potentiometer for controlling the CCIC (Constant Color Intensity Control) illumination intensity
2. Potentiometer for controlling the IsoCol color temperature

The transmitted-light base TL RCI has two electronic potentiometers that control the color intensity (1) and color temperature (2).

The controller for the color temperature simultaneously serves as an electronic shutter:

- To interrupt your work, click the potentiometer (2).
- Click again to switch on the illumination. The electronics return to the previously configured settings.

## Using a USB mouse (only TL RCI)

The Leica USB mouse controls the CCIC and dimming function of the TL RCI base. Connect the mouse to the corresponding USB port of the base.

- The scroll wheel of the mouse is occupied by default with the CCIC control system and is used to control the illumination intensity.
- To switch the illumination on or off, briefly click the scroll wheel.
- To enter or exit dimming mode, click and hold down the scroll wheel for longer than 2 seconds.

# Leica TL RC / Leica TL RCI: Operation

## Setting the relief contrast

The two switches on the left side of the transmitted-light base TL RC/TL RCI activate two built-in flaps. The outer switch (1) controls the inverted relief contrast, and the inner switch (2) adjusts the positive relief contrast.

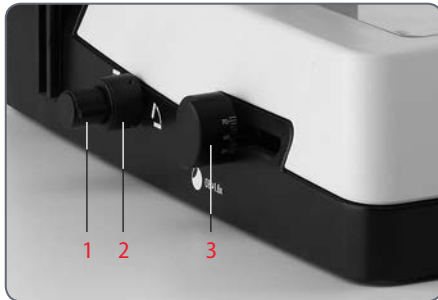

1. Switch for adjusting the inverted relief contrast
2. Switch for adjusting the positive relief contrast
3. Deflection mirror

Depending on the flap position, a part of the opening of the built-in Fresnel lenses are covered, which results in the different contrast effects. Phase structures typically act as spatial, relief-type images – in the positive relief contrast like hills, in the inverted relief contrast like valleys.



Increased contrast without relief is attained if both diaphragms are set to 45°. A gap-like illuminated area is created. By tilting the deflection mirror slightly, you can move the gap over the entire field of view and quickly toggle between positive and negative relief images. The dynamic effect makes it easy to distinguish phase structures from amplitude structures.

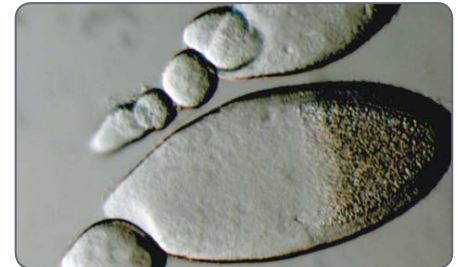

# Leica TL RCI: Methods in Transmitted Light

## **Vertical bright-field illumination**

Suitable for stained amplitude specimens with sufficient contrast.

The light beams are deflected vertically through the specimen. This results in an accurate bright field with maximum brightness.

## **Inclined transmitted light**

Suitable for semitransparent, opaque specimens such as foraminifera and fish eggs. Move the deflection mirror until the desired data are visible.

## **Single-sided dark field**

Suitable for fixed specimens and fine structures.

The flatter the angle at which the light beams are deflected into the specimen plane, the darker the substrate appears. A dark field-like transmitted light is created. Outlines, fine edges and structures are bright, in contrast with the dark background, through diffraction of the light beams on the dark background.

# Leica TL RCI: Relief Images

## Starting position

1. Push the deflection mirror all the way back towards the column.
2. Turn the deflection mirror into the notch position at an angle of 45°.

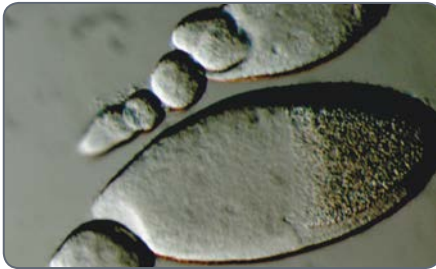

## Positive relief contrast

Suitable for semitransparent and transparent specimens. The phase structures look like hills.

The effect can be strengthened or weakened by gently tilting the deflection mirror.



## Negative relief contrast

Suitable for semitransparent and transparent specimens. These settings result in a negative relief contrast. Phase structures look like valleys.

The effect can be strengthened or weakened by gently tilting the deflection mirror.



# Leica TL RCI: Relief Images (Continued)

## Dynamic relief contrast

Suitable for semitransparent and transparent specimens.

By tilting the deflection mirror slightly, you can move the gaps over the entire field of view and quickly toggle between positive and negative relief images. The dynamic effect makes it easy to distinguish phase structures from amplitude structures.

## Constraints

The relief methods provide good results from mid-zoom to high magnifications and with 1×, 1.6× and 2× magnifications. In the lower zoom half and with weaker specimens, the object field may not be uniformly illuminated.

We recommend using the transmitted-light base with 1× or higher objectives, and not objectives with a long focal length.

# Using Filters

## Filters for TL RC and TL RCI

The transmitted-light bases TL RC and TL RCI can be equipped with up to three filters – available as accessories – simultaneously. By customer request, the filters are also available as one-off items.

1. Switch off the light source or click (TL RCI) the button for the shutter.



2. Take the empty filter from an available filter slot in the filter holder.
3. Insert the desired filter.



4. Switch the light source back on.

## Daylight filter for TL ST

A daylight filter is also available for the transmitted-light Base TL ST.



# Leica IsoPro (Non-motorized): Controls

## Operating the cross-stage IsoPro

1. To move the stage in X direction, rotate the outer knob.
2. To move the stage in Y direction, rotate the inner control ring.

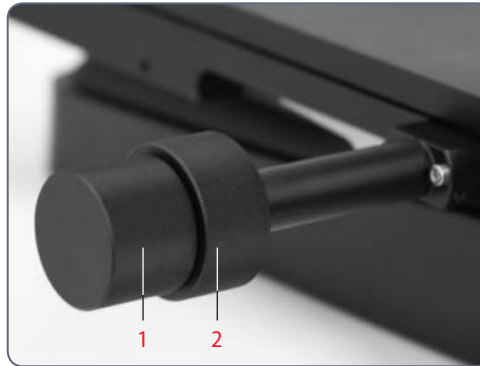

# Leica IsoPro (Motorized): Controls

IsoPro

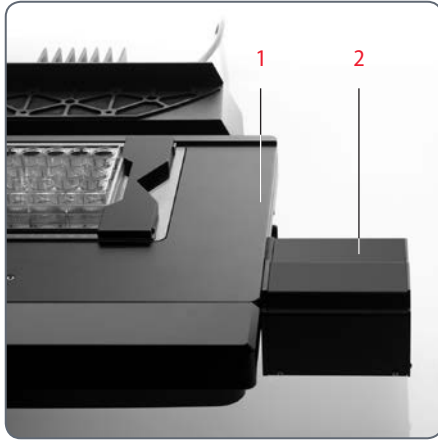

1. Motorized cross-stage Leica IsoPro
2. Housing with motorization

X-Y stage DCI module

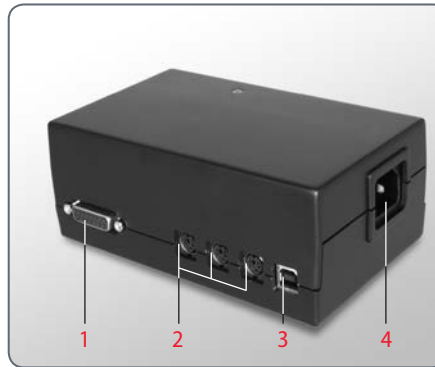

1. Sub-D interface for Leica SmartMove
2. 3 CTL2 interfaces
3. USB interface (type B)
4. Socket for grounded power cable

Leica PSC controller

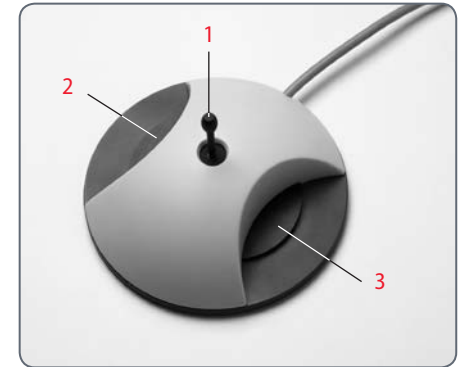

1. Quick control/memory function
2. Fine control in X direction
3. Fine control in Y direction

# Accessories

## Leica Hand Wheel and Foot Switch



Up to five foot switches can be configured with a microscope system. They can be programmed in LAS or LAS X to control focus, illumination, and individual memory positions.



The hand wheel is designed to control the motor focus.

# Leica SmartTouch



With the touchscreen of the Leica SmartTouch, you can control your experiment procedures with a few hand movements and never lose sight of all your important optical parameters.

The most important control functions on the control unit can be adjusted to your specific needs with freely programmable rotary knobs and function buttons.

## Controls

The functions of the individual knobs and screen elements can be configured both directly on the Leica SmartTouch and using the Leica Application Suite.

The standard configuration when shipped from the factory is as follows:

- Top part of the knob = zoom
- Upper part of the knob = focus

For a detailed description of the functions and settings, please refer to the Leica SmartTouch manual or the Leica Application Suite help file.

# Leica PSC Controller

## Use

The Leica PSC controller gives you precision control of the Leica IsoPro motorized cross-stage.

## Connection

Connect the Leica PSC controller and the Leica IsoPro motorized cross-stage.



## Passing over the specimen quickly

- Move the joystick in any desired direction (including diagonally) to quickly control the cross-stage.



## Fine control of the cross-stage

The motorized Leica IsoPro cross-stage offers an accuracy of up to 0.25 $\mu$ m. To move to a position with maximum accuracy, use the left and right knobs on the joystick.

## Control by LAS

The instructions for controlling the Leica IsoPro using the Leica Application Suite are provided in the software's help file.

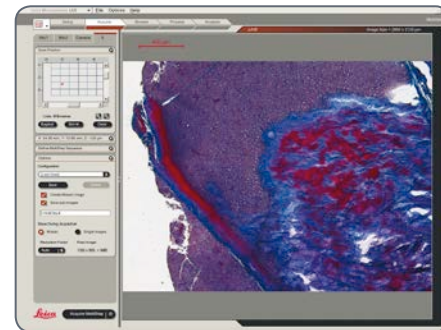

# Dimensional Drawings

# Leica M125 C / Leica M165 C

Leica M125 C / Leica M165 C with incident light base and new focusing column  
(dimensions in mm)

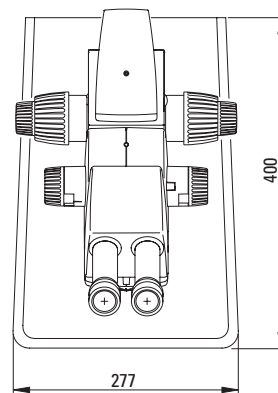
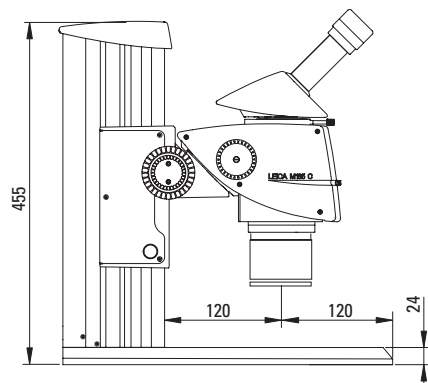
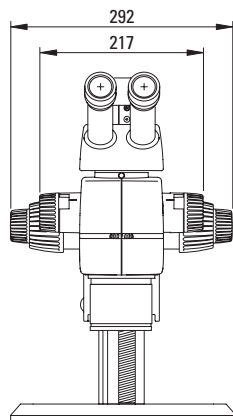



## Leica M125 C / Leica M165 C (Continued)

Leica M125 C / Leica M165 C with transmitted-light base TL ST and manual focus  
(dimensions in mm)

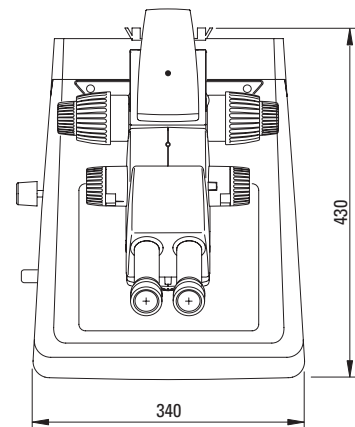
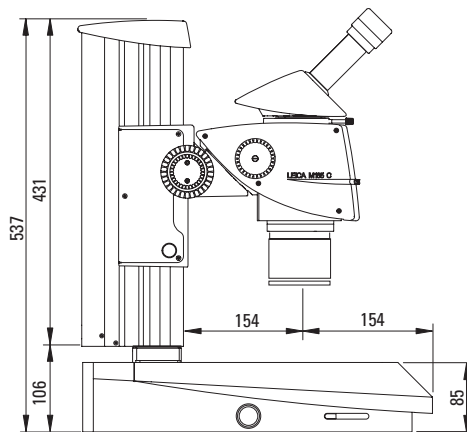
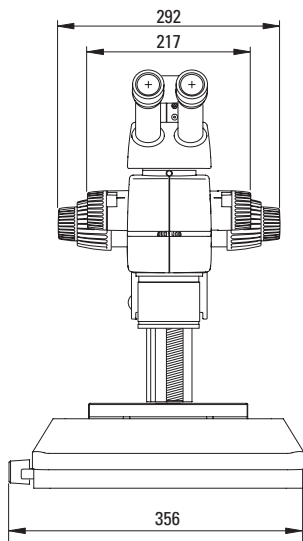

# Leica M125 C / Leica M165 C (Continued)

Leica M125 C / Leica M165 C with transmitted-light stand TL RC and manual focus  
(dimensions in mm)

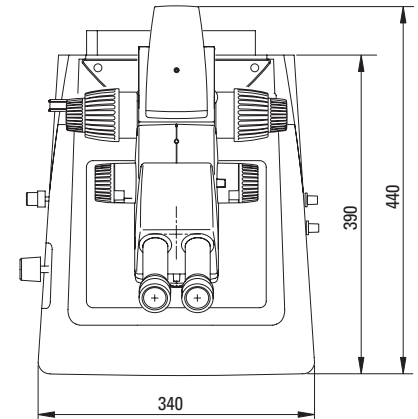
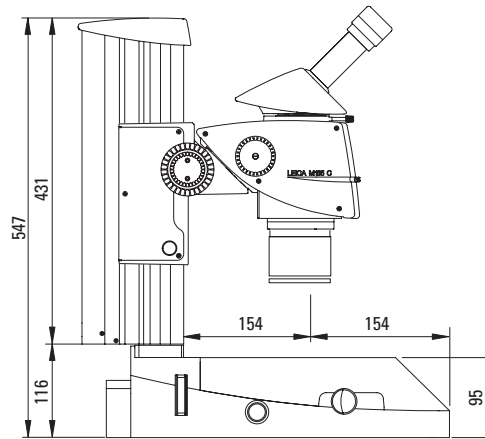
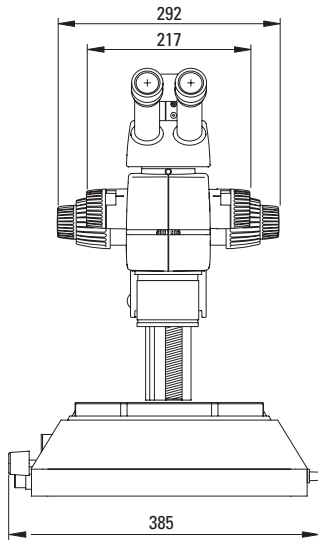

## Leica M125 C / Leica M165 C (Continued)

Leica M125 C / Leica M165 C with transmitted-light stand TL RC, manual cross-stage Leica IsoPro and manual focus  
(dimensions in mm)

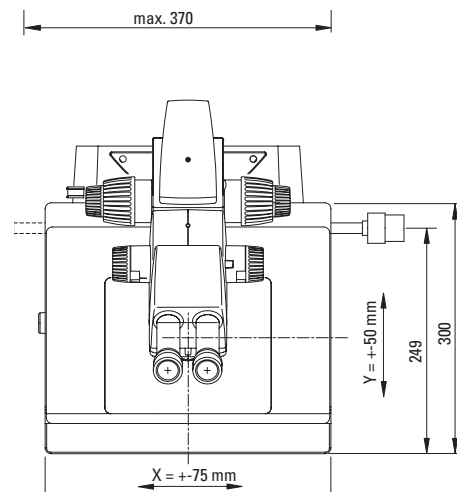
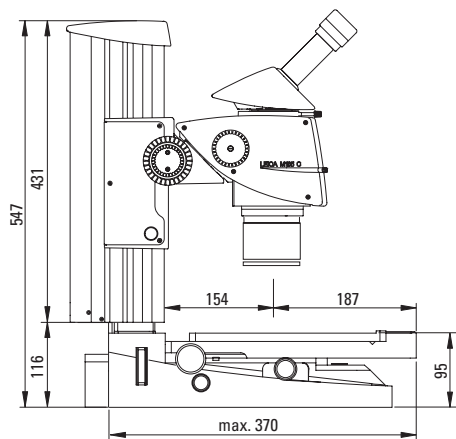
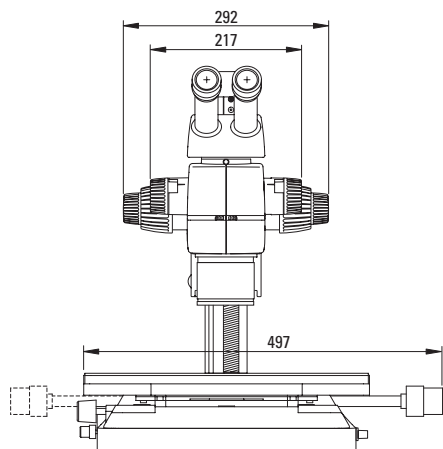

# Leica M205 C

Leica M205 C with transmitted-light stand TL ST and manual focusing drive  
(dimensions in mm)

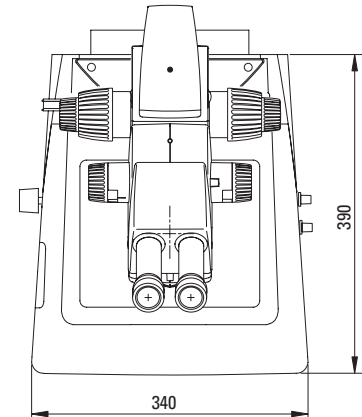
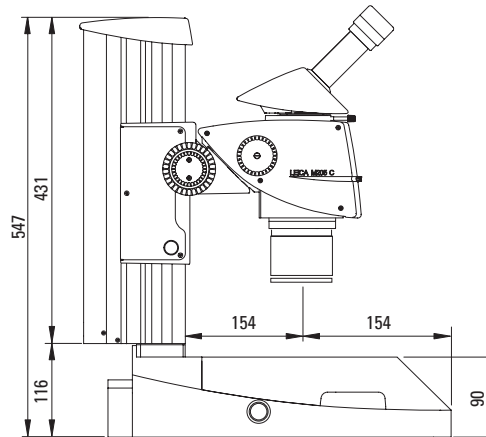
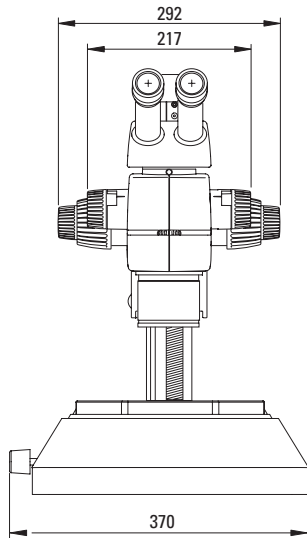

## Leica M205 C (Continued)

Leica M205 C with transmitted-light stand TL RCI and manual focusing drive  
(dimensions in mm)

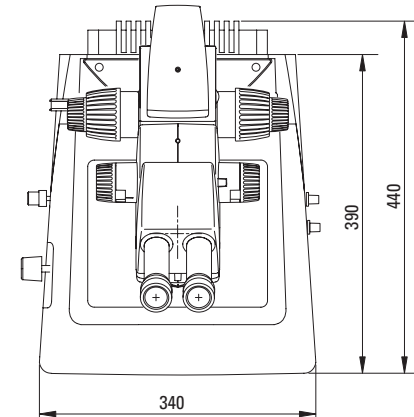
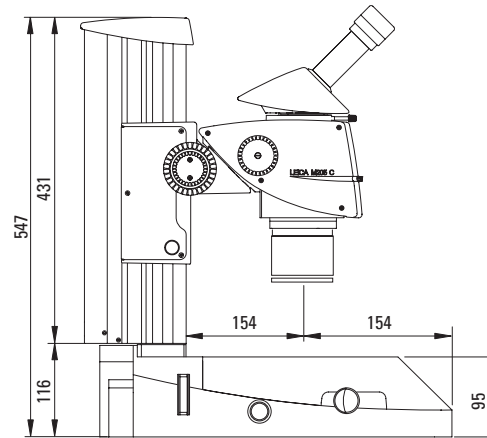
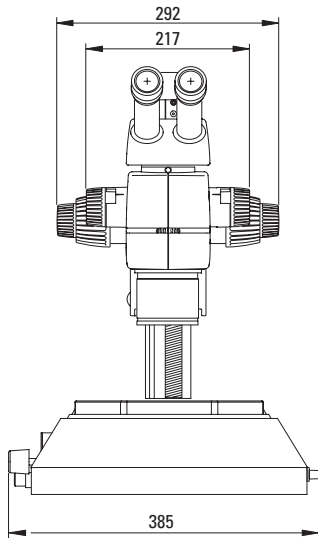

# Leica M205 C (Continued)

Dimensions of Leica M205 C with transmitted-light stand TL RCI, manual cross-stage Leica IsoPro and manual focus (dimensions in mm)

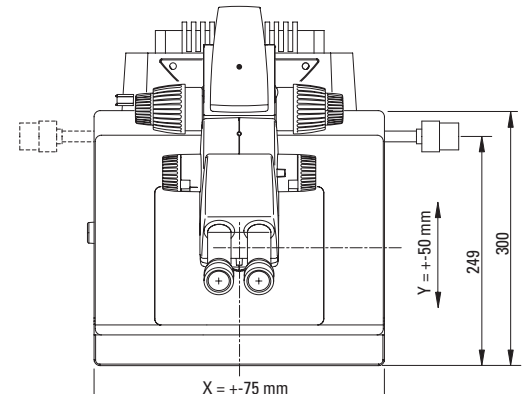
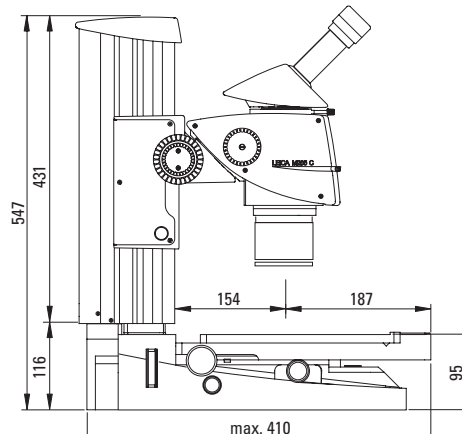
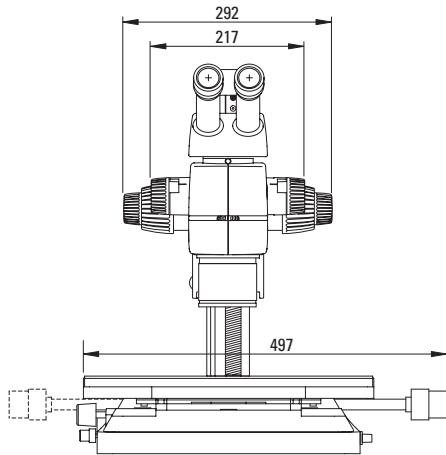

# Leica LED5000 MCI

Leica LED5000 MCI  
(dimensions in mm)

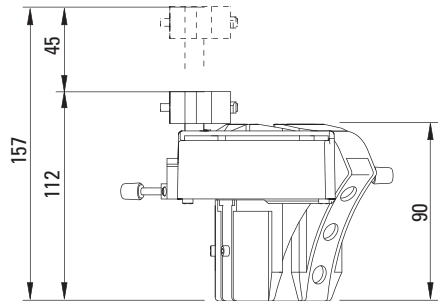
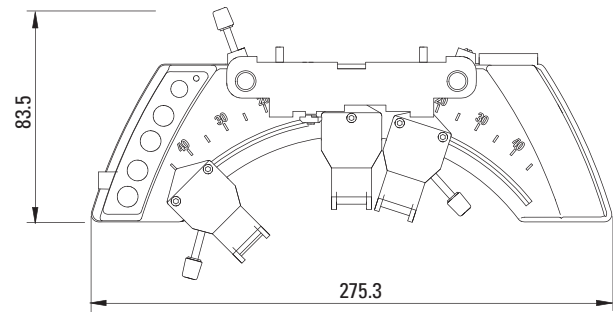
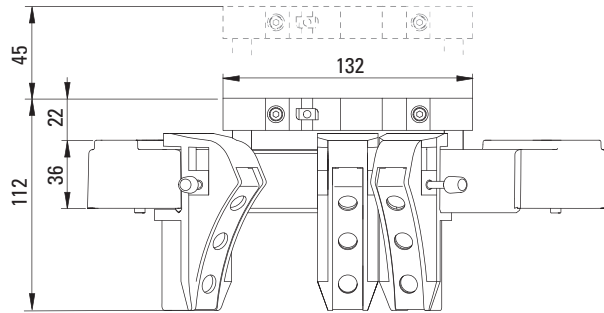

# Leica LED5000 RL

Leica LED5000 RL  
(dimensions in mm)

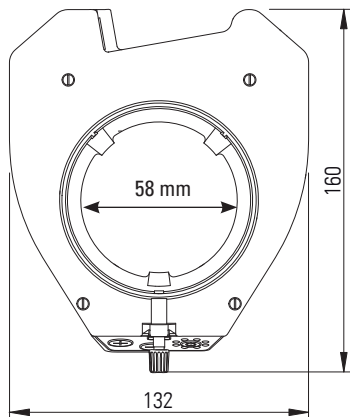
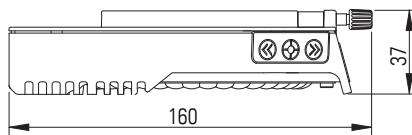
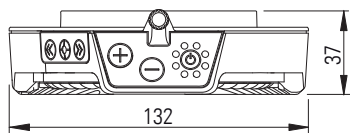



# Leica LED5000 NVI

Leica LED5000 NVI for high-performance stereo microscopes  
(dimensions in mm)

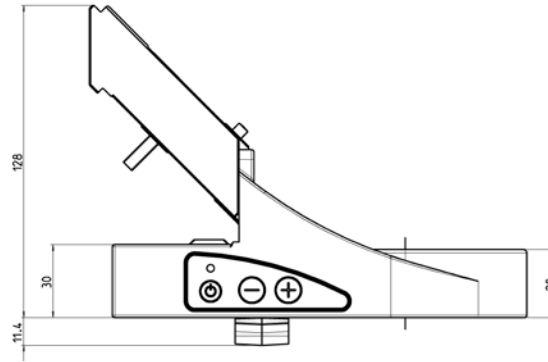
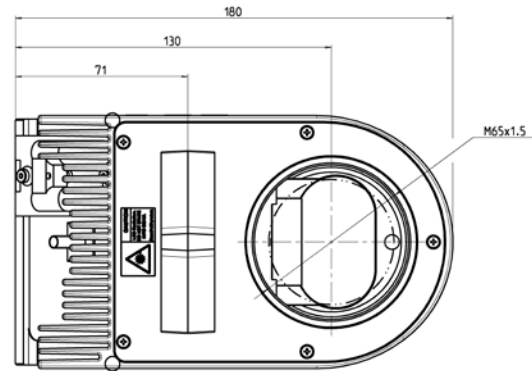
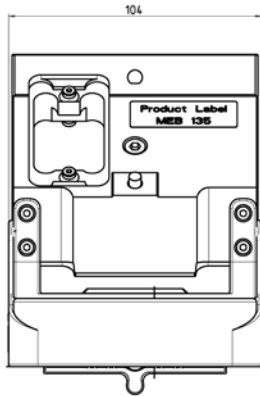

# Specifications for the Bases

## Transmitted-light Base Leica TL ST

Light source	Halogen lamp 12 V/20 W
Quick illuminant change	Yes
Illuminated area	50 mm
Power supply unit	Input voltage 100–240 V~, frequency 50–60 Hz energy consumption 30 W max., ambient temperature 10–40 °C
Connections	Power plug, power switch
Weight	7.4 kg

### **Illumination types**

Bright field	Yes
Dark field	Yes (single-sided)
Oblique light	No
Relief Contrast System (RC)	No
CCIC (Constant Color Intensity Control)	No
Internal shutter/lamp control	No
Integrated filter holder	Yes
Coated optics for increasing the color temperature	Yes
Matching of high num. aperture	No
Remote control options	No
AntiShock Pads	Yes
Dimensions (W×H×D)	340×430×85 mm

## Transmitted-light Base Leica TL BDFD

Light source	External via cold light source
Illuminated area	40 mm
Connections	Connection for cold light guide, active f=10 mm, end tube f=13 mm
Weight	5.8 kg

### Illumination types

Bright field	Yes
Dark field	Yes
Oblique light	No
Relief Contrast System (RC)	No
CCIC (Constant Color Intensity Control)	No
Internal shutter/lamp control	Yes*
Integrated filter holder	No
Coated optics for increasing the color temperature	No
Matching of high num. aperture	Yes**
Remote control options	Yes***
AntiShock Pads	Yes
Dimensions (W×H×D)	340×390×90 mm

\*With cold light source Leica CLS150 LS    \*\*Concave mirror    \*\*\* With external light source

## Leica TL RC / Leica TL RCI

	Leica TL RC	Leica TL RCI
Light source	External via cold light source	Halogen lamp 12 V/20 W
Quick illuminant change	–	Yes
Illuminated area	35 mm	35 mm
Power supply unit	–	100–240 V~, frequency 50–60 Hz energy consumption 30 W max., ambient temperature 10–40 °C
Connections	Connection for cold light guide, active f=10 mm, end tube f=13 mm	1×USB type A, 1×USB type B, 2×CAN-BUS
Weight	6.0 kg	7.2 kg

### Illumination types

Bright field/dark field	Yes/yes	Yes/yes
Oblique light/Relief Contrast System (RC)	Yes/yes	Yes/yes
CCIC (Constant Color Intensity Control)	No	Yes
Internal shutter/lamp control	Yes**	Yes
Integrated filter holder	Yes	Yes
Coated optics for increasing the color temperature	Yes	Yes
Matching of high num. aperture	Yes***	Yes***
Remote control options	Yes****	Yes
AntiShock Pads	Yes	Yes
Dimensions of base (W×H×D)	340×390×95 mm	340×440×95 mm

\* Single-sided \*\*With cold light source Leica CLS150 LS \*\*\*Concave mirror \*\*\*\* With external light source

## Leica IsoPro Motorized XY Stage

Compatibility	Leica incident light base and TL bases (TL BFDF, TL RC, TL RCI)
Stage size (L × W × H)	335.5 mm × 370 mm × 41.5 mm
Travel	152 mm × 102 mm (6" × 4")
Speed X,Y	30 mm/s
Motor resolution X,Y	0.25 μm
Repeatability X,Y	± 2 μm
Positioning accuracy X,Y	±20 μm over the entire travel range
Hysteresis X, Y	30 μm
Motor	Direct current (DC) motor with encoder
Backlash	Slack-free
Adapter	All adapters for TL bases
Acceleration	S-shaped acceleration
Computer connection	USB
Control options	Leica PSC, Leica Smart Move, Leica LAS via PC
Power supply	Input: 100–240 VAC 50/60 Hz 1.0 A Output: 15 VDC 2.66 A 40 W MAX

# Appendix

# Calculating the Total Magnification and Field of View Diameter

## Parameter

MO	Magnification of objective
ME	Magnification of eyepiece
z	Magnification changer position
q	Tube factor, e.g. 1.5× for coaxial incident light, 1.6× for 45° ErgoTube
r	Factor 1.25× if the planachromatic and planapochromatic objectives of the MZ125/MZ16 are used on the MS5, MZ6, MZ75 or MZ95
NFOV	Field number of the eyepiece. Field numbers are printed on the eyepieces: 10× = 21, 16× = 14, 25× = 9.5, 40× = 6.

## Example

MO	1× objective
ME	25×/9.5 eyepiece
z	Zoom position 4
q	Coaxial reflected light 1.5×, tube factor
r	Factor 1.25×

### Calculation example: magnification in binocular tube

$$\begin{aligned}
 \text{MTOT VIS} &= \text{MO} \times \text{ME} \times z \times q \times r \\
 &\text{or} \\
 &1 \times 25 \times 4 \times 1.5 \times 1.25 = 187.5\times
 \end{aligned}$$

### Calculation example: field of view diameter in the specimen

$$\text{Ø OF: } \frac{N_{\text{FOV}}}{\text{MO} \times z \times q \times r}$$



# Care, Maintenance, Contact Persons

We hope you enjoy using your high-performance microscope. Leica microscopes are renowned for their robustness and long service life. Observing the following care and cleaning tips will ensure that even after years and decades, your Leica microscope will continue to work as well as on the very first day.

## Warranty benefits

The guarantee covers all faults in materials and manufacture. It does not, however, cover damage resulting from careless or improper handling.

## Contact address

However, if your instrument should no longer function properly, contact your technician, your Leica representative or Leica Microsystems (Switzerland) AG, CH-9435 Heerbrugg.

## E-mail contact:

[stereo.service@leica-microsystems.com](mailto:stereo.service@leica-microsystems.com)

## Care

- Protect your microscope from moisture, fumes and acids and from alkaline, caustic and corrosive materials and keep chemicals away from the instruments.
- Plugs, optical systems and mechanical parts must not be disassembled or replaced, unless doing so is specifically permitted and described in this manual.
- Protect your microscope from oil and grease.
- Do not grease guide surfaces or mechanical parts.

## Care, Maintenance, Contact Persons (Continued)

### Protection from dirt

Dust and dirt will affect the quality of your results.

- Put a dust cover over the instrument when it will not be used for a long time.
- Use dust caps to protect tube openings, tubes without eyepieces, and eyepieces.
- Keep accessories in a dust-free place when not in use.

### Cleaning polymer components

Some components are made of polymer or are polymer-coated. They are, therefore, pleasant and convenient to handle. The use of unsuitable cleaning agents and techniques can damage polymers,

### Permitted measures

- Clean the microscope (or parts of it) using warm soapy water, then wipe using distilled water.
- For stubborn dirt, you can also use ethanol (industrial alcohol) or isopropanol. When doing so, follow the corresponding safety instructions.
- Remove dust with a pneumatic rubber bulb or with a soft brush.
- Clean objectives and eyepieces with special optic cleaning cloths and with pure alcohol.



Leica Microsystems (Schweiz) AG · Max-Schmidheiny-Strasse 201 · 9435 Heerbrugg, Switzerland  
T +41 71 726 34 34 · F +41 71 726 34 44

[www.leica-microsystems.com](http://www.leica-microsystems.com)

CONNECT  
WITH US!

